



ZAPI[®] S.p.A.

**ELECTRONIC • OLEODYNAMIC • INDUSTRIAL
EQUIPMENTS CONSTRUCTION**

Via Parma, 59 – 42028 – POVIGLIO (RE) – ITALY
Tel +39 0522 960050 (r.a.) – Fax +39 0522 960259
e-mail: zapi@zapispa.it – web: www.zapispa.it



User Manual

DUALAC2/ &HP/POWER INVERTER



The contents of this publication is a ZAPI S.p.A. property; all related authorizations are covered by Copyright. Any partial or total reproduction is prohibited.

Under no circumstances will Zapi S.p.A. be held responsible to third parties for damage caused by the improper use of the present publication and of the device/devices described in it.

Zapi spa reserves the right to make changes or improvements to its products at any time and without notice.

The present publication reflects the characteristics of the product described at the moment of distribution. The publication therefore does not reflect any changes in the characteristics of the product as a result of updating.



ZAPI® is a registered trademark property of Zapi S.p.A.

NOTES LEGEND



The symbol aboard is used inside this publication to indicate an annotation or a suggestion you should pay attention.



The symbol aboard is used inside this publication to indicate an action or a characteristic very important as for security. Pay special attention to the annotations pointed out with this symbol.

Contents

1	INTRODUCTION	6
2	SPECIFICATION	7
2.1	Technical specifications - "Dualac2"	7
2.1.1	Block diagram	7
2.2	Technical specifications - "Dualac2&hp"	8
2.2.1	Block diagram	8
2.2.2	Chopper block diagram.....	9
2.3	Technical specifications - "Dualac2 Power"	9
2.3.1	Block diagram	9
2.4	Technical specifications - "Dualac2&hp Power"	9
2.4.1	Block diagram	10
3	SPECIFICATION FOR THE INPUT DEVICES FILLING UP THE INSTALLATION KIT.....	11
3.1	Microswitches	11
3.2	Accelerator unit.....	11
3.3	Other analog control unit	12
3.4	Speed feedback.....	12
3.5	Steering angle transducer.....	12
4	INSTALLATION HINTS.....	15
4.1	Material overview.....	15
4.1.1	Connection cables	15
4.1.2	Contactors.....	15
4.1.3	Fuses	15
4.2	Installation of the hardware.....	15
4.2.1	Positioning and cooling of the controller	16
4.2.2	Wirings: power cables.....	16
4.2.3	Wirings: CAN connections and possible interferences	16
4.2.4	Wirings: I/O connections	19
4.2.5	Encoder installation.....	19
4.2.6	Main contactor and key connection	20
4.2.7	Insulation of truck frame.....	20
4.3	Protection and safety features	20
4.3.1	Protection features.....	20
4.3.2	Safety Features.....	21
4.4	EMC.....	21
4.5	Various suggestions	23
5	OPERATIONAL FEATURES	24
5.1	Diagnosis	24
6	DESCRIPTION OF THE CONNECTORS.....	26
6.1	Connectors of the logic - "Dualac2" and "Dualac2 Power"	26
6.2	Connectors of the logic - "Dualac2&hp" and "Dualac2&hp Power"	28
6.3	CANBUS connector description.....	30
6.3.1	"Dualac2" Controller in stand-alone configuration	30
6.3.2	"Dualac2" Controller is a termination module in the canbus net.....	31
6.3.3	"Dualac2" Controller is a repetition module in the canbus net.....	31
6.4	Description of power connections.....	32
6.4.1	"Dualac2"	32
6.4.2	"Dualac2 Power"	33

6.4.3	"Dualac2&hp"	34
6.4.4	"Dualac2&hp Power"	36
7	DRAWINGS.....	38
7.1	Mechanical drawing.....	38
7.1.1	Dimensions of "Dualac2"	38
7.1.2	Dimensions of "Dualac2 Power"	39
7.1.3	Dimensions of "Dualac2&hp"	40
7.1.4	Dimensions of "Dualac2&hp Power"	41
7.2	Connection drawing - "Dualac2" and "Dualac2 Power" standalone	42
7.3	Connection drawing - "Dualac2&hp" and "Dualac2&hp Power" standalone	43
8	PROGRAMMING & ADJUSTMENTS USING DIGITAL CONSOLE	44
8.1	Adjustments via Console.....	44
8.2	Description of Console & Connection.....	44
8.3	Description of Standard Console Menu.....	45
8.3.1	"Dualac2" and "Dualac2 Power" menu configuration	45
8.3.2	"Dualac2&hp" and "Dualac2&hp Power" menu configuration.....	47
8.4	Function configuration	49
8.4.1	"Dualac2" and "Dualac2 Power" - Master.....	49
8.4.2	"Dualac2" and "Dualac2 Power" - Slave.....	52
8.4.3	"Dualac2&hp" and "Dualac2&hp Power" - Master	52
8.4.4	"Dualac2&hp" and "Dualac2&hp Power" - Slave	52
8.5	Parameter regulation.....	58
8.5.1	"Dualac2" - Master.....	58
8.5.2	"Dualac2" - Slave.....	60
8.5.3	"Dualac2&hp" – Master	60
8.5.4	"Dualac2&hp" - Slave	60
8.6	Programming console functions	65
8.6.1	"Dualac2" and "Dualac2 Power"	65
8.6.2	"Dualac2&hp" and "Dualac2&hp Power"	65
8.7	Sequence for Ac Traction Inverter setting	66
8.8	Sequence for Dc Pump Chopper setting (DUALAC&HP only)	67
8.9	Tester: description of the function	68
8.9.1	"Dualac2" and "Dualac2 Power" - Master.....	68
8.9.2	"Dualac2" and "Dualac2 Power" - Slave.....	69
8.9.3	"Dualac2&hp" and "Dualac2&hp Power" – Master	70
8.9.4	"Dualac2&hp" and "Dualac2&hp Power" - Slave	70
9	OTHER FUNCTIONS	73
9.1	Save and Restore function	73
9.2	Description of Alarms menu	73
9.3	Description of Console Program Vacc function	74
10	"DUALAC2" AND "DUALAC2&HP" INVERTER DIAGNOSTIC	76
10.1	Traction related fault codes	76
10.2	Analysis of traction related alarms displayed on console	81
10.3	Pump related fault codes.....	85
10.4	Analysis of pump related alarms displayed on console.....	86
11	RECOMMENDED SPARE PARTS FOR INVERTER	88
12	PERIODIC MAINTENANCE TO BE REPEATED AT TIMES INDICATED.....	89

APPROVAL SIGNS

COMPANY FUNCTION	INITIALS	SIGN
GRAPHIC AND LAYOUT	FF	
PROJECT MANAGER	FG	
TECHNICAL ELECTRONIC MANAGER VISA	PP	
SALES MANAGER VISA	PN	

Publication N°: **AE9ZP0BD**

Edition: **December 2006**

1 INTRODUCTION

Within the ZAPIMOS family, the DUALAC2 inverter is the model suitable for control of pairs of 3.0kW to 7.0kW motors. The DUALAC2&HP can also control a DC-Series pump motor, up to 15kW. These controllers have been expressly designed for battery powered applications, traction and hydraulic functions. They are fit for electric trucks, utility cars, tractors.

2 SPECIFICATION

2.1 Technical specifications - "Dualac2"

- Inverter for pairs of AC asynchronous 3-phase motors
- Regenerative braking functions
- Can-bus interface
- Flash memory (256 Kbytes On-Chip Program Memory, each microcontroller)
- Digital control based upon a microcontroller (one per each motor)
- Voltage:24 - 36 - 48 - 72 – 80 V
- Maximum current (24 V):.....350 A (RMS) for 3' per each motor
- Maximum current (36/48 V):.....320 A (RMS) for 3' per each motor
- Maximum current (72/80 V):.....300 A (RMS) for 2' per each motor
- Operating frequency:.....8 kHz
- External temperature range:-30 °C ÷ 40 °C
- Maximum inverter temperature (at full power):75 °C

2.1.1 Block diagram

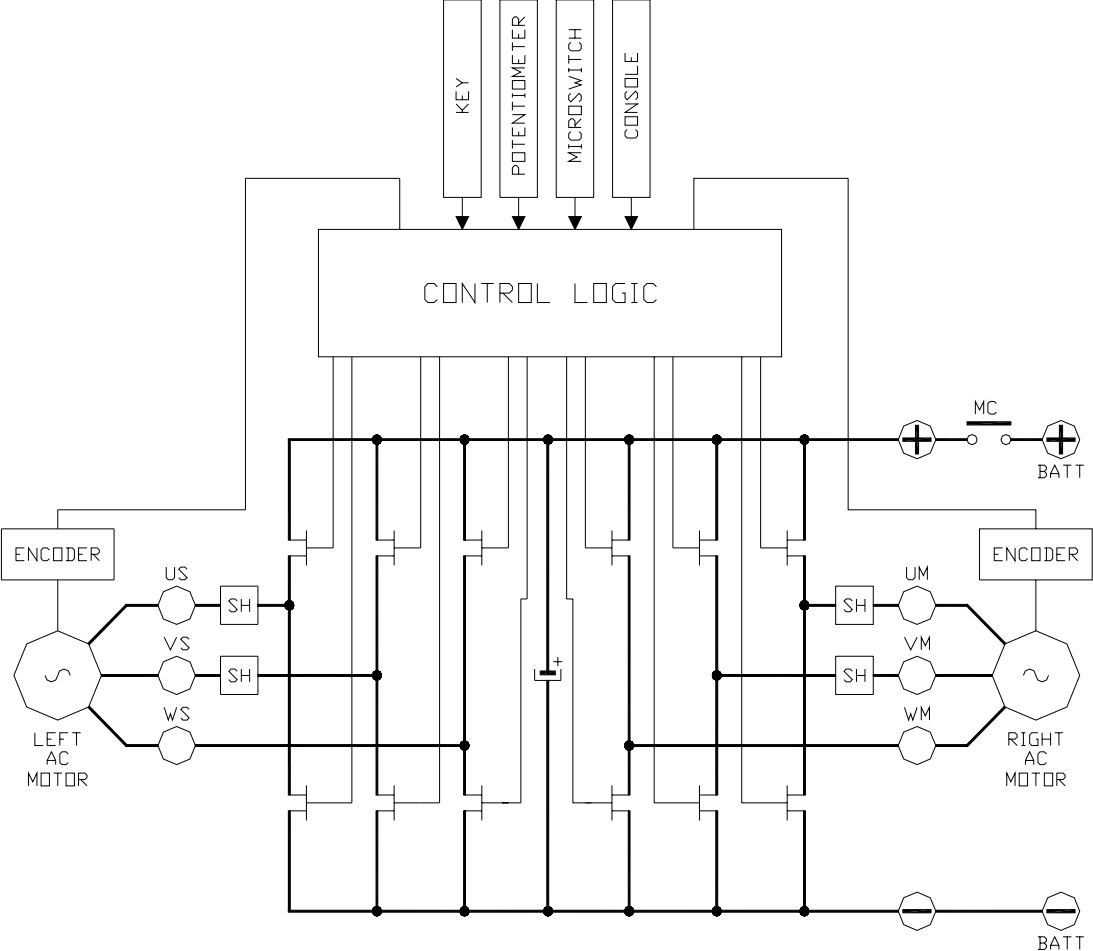

2.2 Technical specifications - "Dualac2&hp"

Inverter for pairs of AC asynchronous 3-phase motors plus chopper for DC series pump motor.

Regenerative braking functions

Can-bus interface

Flash memory (256 Kbytes On-Chip Program Memory, each microcontroller)

Digital control based upon a microcontroller (one per each AC motor)

Voltage:..... 24 - 36 - 48 - 72 – 80 V

Maximum current (24 V): 350 A (RMS) for 3' per each motor

Maximum current (36/48 V): 300 A (RMS) for 3' per each motor

Maximum current (72/80 V): 300 A (RMS) for 2' per each motor

Chopper maximum current (24 V): 500 A for 2'

Chopper maximum current (36/48 V): 450 A for 2'

Chopper maximum current (72/80 V): 300 A for 2'

Operating frequency: 8 kHz

External temperature range: -30 °C ÷ 40 °C

Maximum inverter temperature (at full power): 75 °C

2.2.1 Block diagram

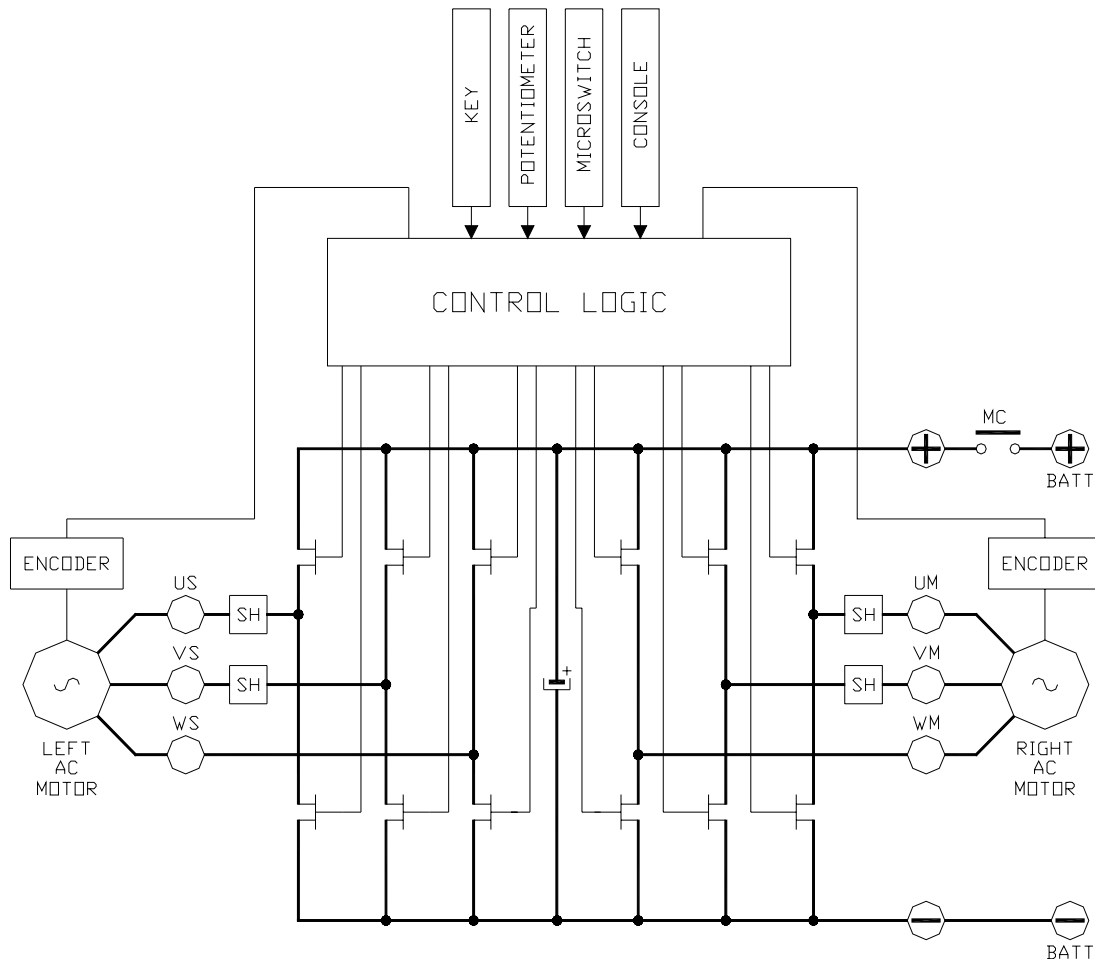

2.2.2 Chopper block diagram

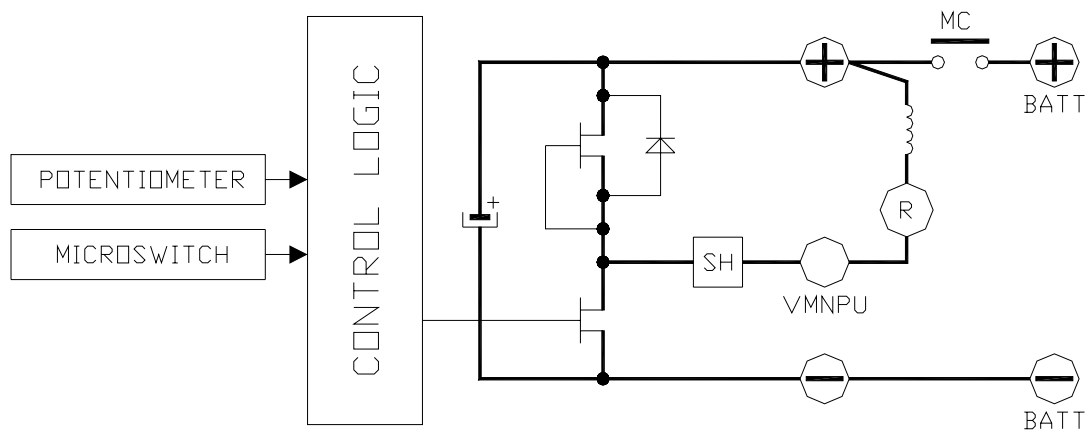

2.3 Technical specifications - "Dualac2 Power"

Inverter for pairs of AC asynchronous 3-phase motors

Regenerative braking functions

Can-bus interface

Flash memory (256 Kbytes On-Chip Program Memory, each microcontroller)

Digital control based upon a microcontroller (one per each AC motor)

Voltage:24 - 36 - 48 - 72 – 80 V

Maximum current (24 V):.....500 A (RMS) for 3' per each motor

Maximum current (36/48 V):.....450 A (RMS) for 3' per each motor

Maximum current (72/80 V):.....400 A (RMS) for 2' per each motor

Operating frequency:.....8 kHz

External temperature range: -30 °C ÷ 40 °C

Maximum inverter temperature (at full power):75 °C

2.3.1 Block diagram

See chapter 2.1.1.

2.4 Technical specifications - "Dualac2&hp Power"

Inverter for pairs of AC asynchronous 3-phase motors plus chopper for DC series pump motor

Regenerative braking functions

Can-bus interface

Flash memory (256 Kbytes On-Chip Program Memory, each microcontroller)

Digital control based upon a microcontroller (one per each AC motor)

Voltage:24 - 36 - 48 - 72 – 80 V

Maximum current (24 V):.....500 A (RMS) for 3' per each motor

Maximum current (36/48 V):.....450 A (RMS) for 3' per each motor

Maximum current (72/80 V):.....400 A (RMS) for 2' per each motor

Chopper maximum current (24 V):.....500 A for 2'

Chopper maximum current (36/48 V):.....450 A for 2'

Chopper maximum current (72/80 V):.....300 A for 2'

Operating frequency:.....8 kHz

External temperature range:-30 °C ÷ 40 °C
Maximum inverter temperature (at full power):75 °C

2.4.1 Block diagram

See chapters 2.2.1 and 2.2.2.

3 SPECIFICATION FOR THE INPUT DEVICES FILLING UP THE INSTALLATION KIT

The DUALAC2 inverter needs some external parts in order to work. The following devices complete the kit for the DUALAC2 installation.

3.1 Microswitches

- The microswitches must have a contact resistance lower than 0.1 ohm and a leakage current lower than 100 μ A.
- When full load connected, the voltage between the key switch contacts must be lower than 0.1 V.
- The microswitches send a voltage signal to the microprocessor when a function request (for ex.: running request) is made.

3.2 Accelerator unit

The accelerator unit can consist of a potentiometer or an Hall effect device. It should be in a 3-wire configuration.

CPOT (C21) signal ranges from 0 to 10 V.

Potentiometer value should be in the 0.5 - 10 kohm range; generally, the load should be in the 1.5 mA to 30 mA range. Faults can occur if it is outside this range.

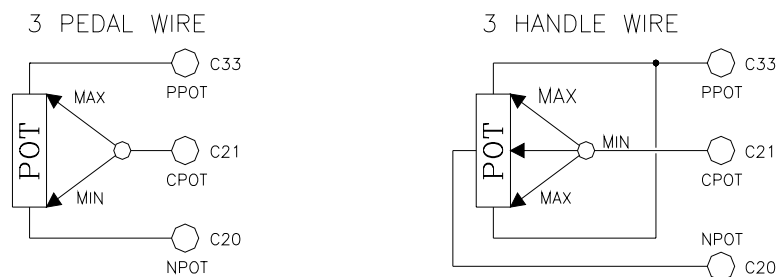

PPOT is the accelerator unit positive supply. It can be either a 5 V output or a 10 V output. The selection of the output voltage is made in the logic card by moving a jumper (factory set).

NPOT is the accelerator unit negative supply. This output is feedback to the μ C A/D converter to test the continuity of the accelerator unit circuit (test of poti wire disconnection).

The Procedure for automatic potentiometer signal acquisition is carried out using the Console. This enables adjustment of the minimum and maximum useful signal level (PROGRAM VACC function), in either direction. This function is unique when it is necessary to compensate for asymmetry with the mechanical elements associated with the potentiometer, especially relating to the minimum level.

The sequence of procedure is described in the programming console manual.

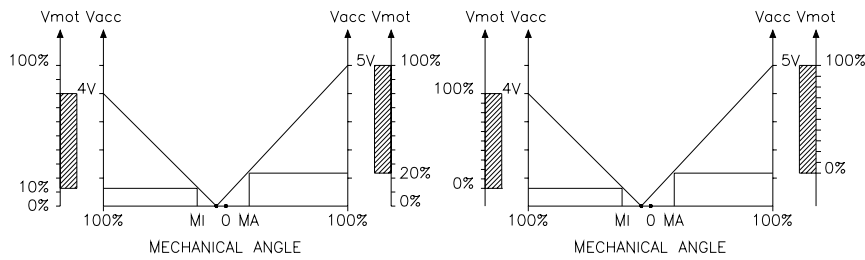

The two graphs show the output voltage from a non-calibrated potentiometer with respect to the mechanical “zero” of the control lever. MI and MA indicate the point where the direction switches close. 0 represents the mechanical zero of the rotation.

The Left Hand graph shows the relationship of the motor voltage without signal acquisition being made. The Right Hand Graph shows the same relationship after signal acquisition of the potentiometer.

3.3 Other analog control unit

- 1) Input C18 is an analog input, whose typical application is for proportional braking. It should be in a 3 wire configuration. Potentiometer value should be in the 0.5-10 kohm range. Generally, the load should be in the 1.5 mA to 30 mA range.
The CPOTB (C18) signal range is from 0 to 5 V or from 0 V to 10 V.
- 2) Connections C25 (PTHERMR) and C24 (NTHERMR) are used for the right motor thermal sensor. Connections C35 (PTHERML) and C34 (NTHERML) are used for the left motor thermal sensor. Sensors can be digital (on/off sensor, normally closed) or analog. See also chapter 8.4 for more explanation.
- 3) In the versions with integrated pump chopper (DUALAC2&HP and DUALAC2&HP POWER), it is possible to input to the controller an analog signal for proportional lifting. This input will be the output of a potentiometer (3 wires, resistance in the 1 to 10 kohm range) or of a Hall Effect device; the load must be below 10 mA. CPOTLIFT (D9) signal has to be within the 0 to 10 V range.

3.4 Speed feedback

The traction motors control is based upon the motor speed feedback. The speed transducer is an incremental encoder, with two phases shifted at 90°. The encoder can be of different types :

- power supply: +5 V or +12 V
- electric output: open collector (NPN or PNP), push-pull

For more details about encoder installation see also chapter 4.2.5.

3.5 Steering angle transducer

Angular position of steered wheels is transduced to an electric information (voltage) by means of a potentiometer, with following characteristics:

- resistance in the 2 kohm to 20 kohm range;
- suggested rotation electric angle: at least 300°;

- positive supply: 5 V or 10 V;
- potentiometer has to be installed in a way that in the "zero" position (straight wheels), poti output voltage is in the middle of the electric range corresponding to a full left-to-right transition of the steered wheels;
- install the potentiometer in a way that, when truck turns right, poti output voltage increases;
- use "SET STEER MIN" and "SET STEER MAX" functions to record the extremes (minimum and maximum) of the potentiometer range; see chapter 8.4.
- use "SET STEER 0-POS" function to record the poti output when the steered wheels are straight; see chapter 8.4.

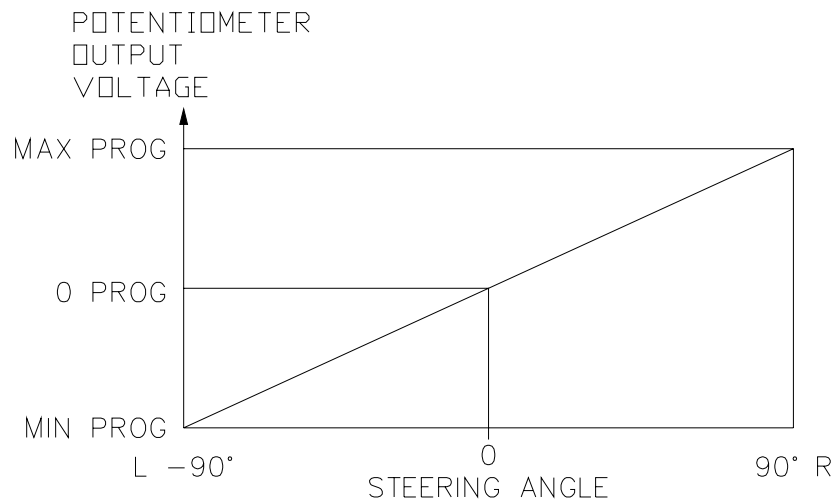

MOTOR MANAGEMENT TABLE

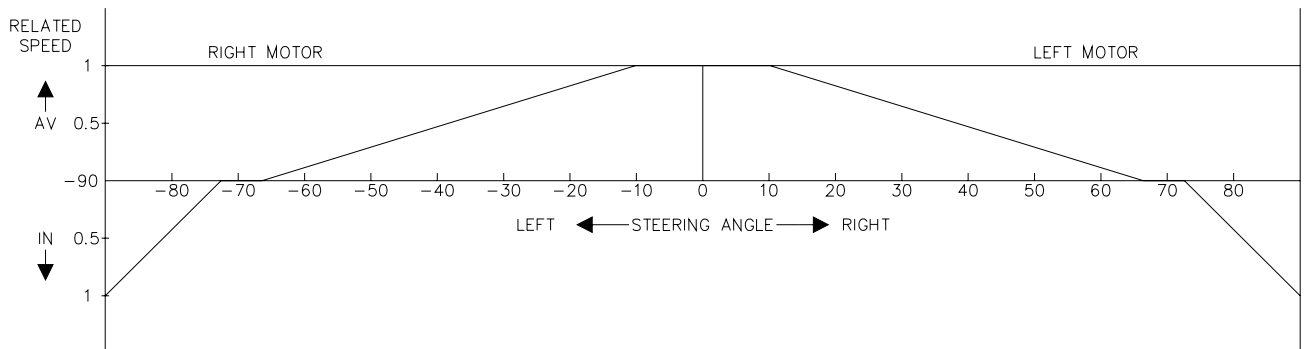

Potentiometer connections

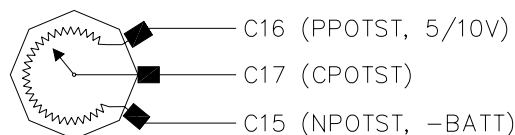

Steering table

The relationship between the two motors speed changes as a function of the steering angle and of the axle/wheeltrack ratio.

While the steering angle is an information coming from the transducer

(potentiometer), the axle/wheeltrack ratio is a constant characteristic of the truck that depends on his dimensions. Actually two steering tables are provided:
 Option #1 = tables for 3 wheels trucks with **driving wheels counter-rotation** (the internal wheel inverts the direction).
 Option #2 = tables for 4 wheels trucks without **driving wheels counter-rotation** (the internal wheel does not invert the direction).
 The truck data have to be communicated to Zapi, so that it is possible to put in the software the correct steering table.
 The correct table selection is done in the SET OPTION menu, see chapter 8.4.

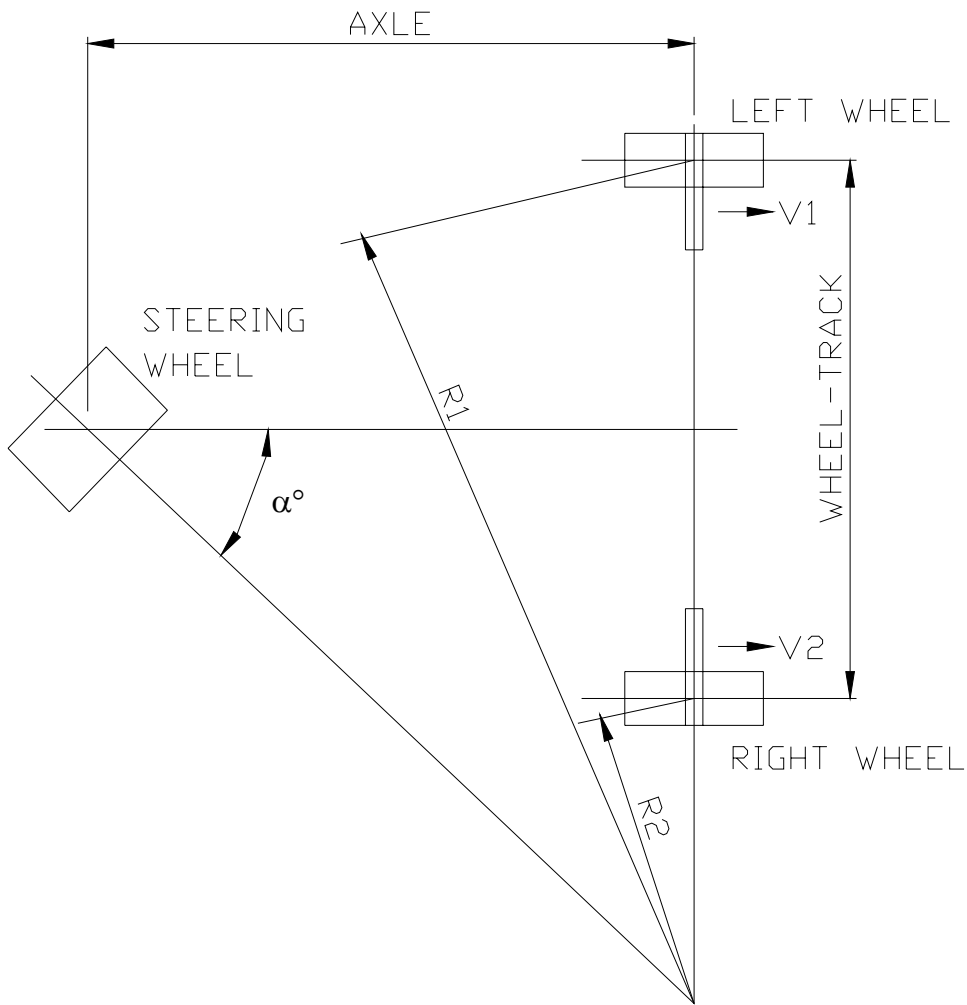

The relationship between the two motors speed is equal to the relationship between the two radius described during the curve.

4 INSTALLATION HINTS

In the description of these installation suggestions you will find some boxes of different colours, they mean:



These are **informations** useful for anyone is working on the installation, or a deeper examination of the content



These are **Warning boxes**, they describe:

- operations that can lead to a failure of the electronic device or can be dangerous or harmful for the operator;
- items which are important to guarantee system performance and safety

4.1 Material overview

Before to start it is necessary to have the required material for a correct installation. Otherwise a wrong choice of cables or other parts could lead to failures/ misbehaviour/ bad performances.

4.1.1 Connection cables

For the auxiliary circuits, use cables of 0.5 mm² section.
For power connections to the motor and to the battery, use cables having section of at least 70 mm².
For the optimum inverter performance, the cables to the battery should be run side by side and be as short as possible.

4.1.2 Contactors

The main contactor must be installed. The LC coil driver is voltage controlled by means of a 1 kHz PWM. The voltage applied to the coil can be adjusted by "Main Cont Voltage" parameter in Config/Adjustment menu. It has to be adjusted to the LC coil nominal voltage.

4.1.3 Fuses

- Use a 10 A Fuse for protection of the auxiliary circuits.
- For protection of the power unit, refer to diagrams. The Fuse value shown is the maximum allowable. For special applications or requirements these values can be reduced.
- For Safety reasons, we recommend the use of protected fuses in order to prevent the spread of fused particles should the fuse blow.

4.2 Installation of the hardware



Before doing any operation, ensure that the battery is disconnected and when all the installation is completed start the machine with the drive wheels raised from the floor to ensure that any installation error do not compromise safety.

After operation, even with the Key Switch open, the internal capacitors may remain charged for some time. For safe operation, we recommend that the battery is disconnected, and a short circuit is made between Battery Positive and Battery Negative power terminals of the inverter using a Resistor between 10 ohm and 100 ohm.

4.2.1 Positioning and cooling of the controller

- Install the inverter with the base-plate on a flat metallic surface that is clean and unpainted.
- Apply a light layer of thermo-conductive grease between the two surfaces to permit better heat dissipation.
- Ensure that the wiring of the cable terminals and connectors is carried out correctly.
- Fit transient suppression devices to the horn, solenoid valves, and contactors not connected to the controller such as those for activating the pump motor.
- The heat generated by the power block must be dissipated. For this to be possible, the compartment must be ventilated and the heat sink materials ample.
- The heat sink material and system should be sized on the performance requirement of the machine. Abnormal ambient air temperatures should be considered. In situations where either ventilation is poor, or heat exchange is difficult, forced air ventilation should be used.
- The thermal energy dissipated by the power block module varies and is dependent on the current drawn and the duty cycle.

4.2.2 Wirings: power cables

- The power cables length must be as short as possible to minimize power losses.
- They must be tightened on controller power posts with a Torque of 13-15 Nm.
- The DUALAC2 module should only be connected to a traction battery. Do not use converters outputs or power supplies. For special applications please contact the nearest Zapi Service Centre.



Do not connect the controller to a battery with a nominal voltage different than the value indicated on the controller label. A higher battery voltage may cause power section failure. A lower voltage may prevent the logic operating.

4.2.3 Wirings: CAN connections and possible interferences



CAN stands for Controller Area Network. It is a communication protocol for real time control applications. CAN operates at data rate of up to 1 Megabits per second.

It was invented by the German company Bosch to be used in the car industry to permit communication among the various electronic modules of a vehicle, connected as illustrated in this image:

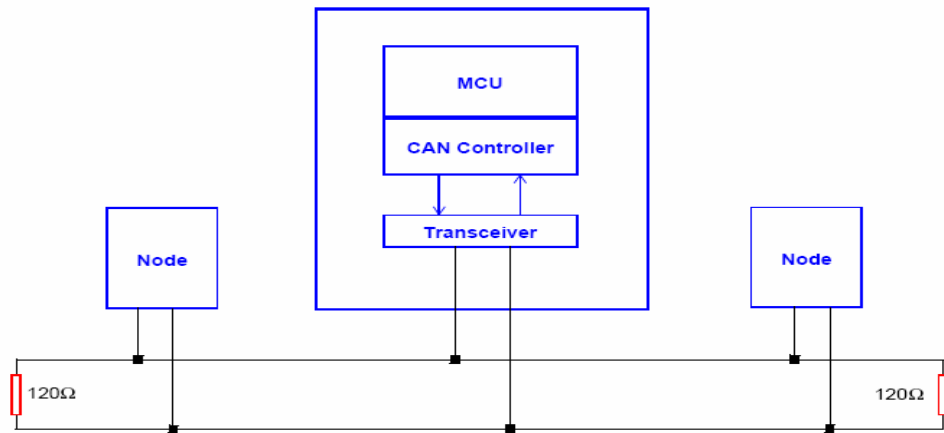

- The best cable for can connections is the twisted pair; if it is necessary to increase the immunity of the system to disturbances, a good choice would be to use a cable with a shield connected to the frame of the truck. Sometimes it is sufficient a simple double wire cable or a duplex cable not shielded.
- In a system like an industrial truck, where power cables carry hundreds of Ampere, there are voltage drops due to the impedance of the cables, and that could cause errors on the data transmitted through the can wires. In the following figures there is an overview of wrong and right layouts of the cables routing.



Wrong Layout:

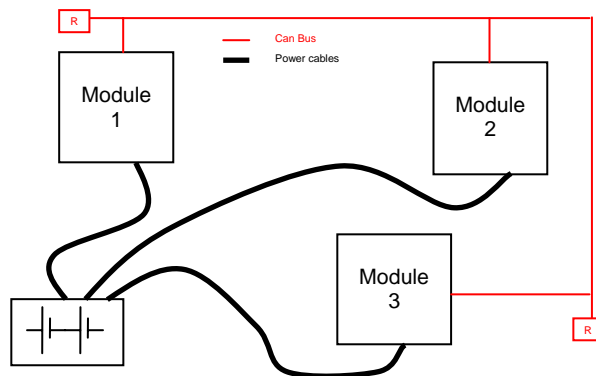

The red lines are can wires.
 The black boxes are different modules, for example traction controller, pump controller and display connected by canbus.
 The black lines are the power cables.

This is apparently a good layout, but can bring to errors in the can line.
 The best solution depends on the type of nodes (modules) connected in the network.
 If the modules are very different in terms of power, then the preferable connection is the daisy chain.



Correct Layout:

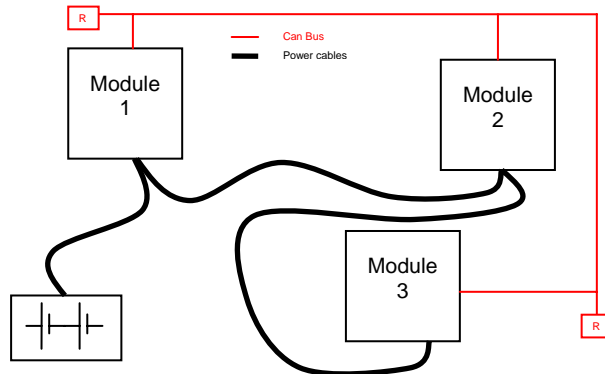

Note: Module 1 power > Module 2 power > Module 3 power

The chain starts from the –BATT post of the controller that works with the highest current, and the others are connected in a decreasing order of power. Otherwise, if two controllers are similar in power (for example a traction and a pump motor controller) and a third module works with less current, the best way to deal this configuration is to create a common ground point (star configuration).



Correct Layout:

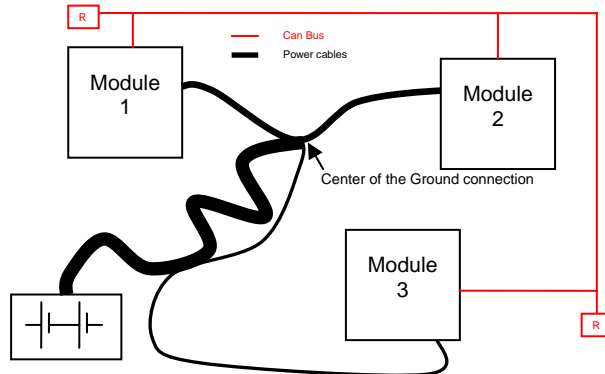

Note: Module 1 power \approx Module 2 power > Module 3 power

In this case the power cables starting from the two similar controllers must be as short as possible. Of course also the diameter of the cable concurs in the voltage drops described before (higher diameter means lower impedance), so in this last example the cable between the minus of the Battery and the common ground point (pointed by the arrow in the image) must be dimensioned taking into account thermal and voltage drop problems.



Can advantages

The complexity of today systems needs more and more data, signal and information must flow from a node to another. CAN is the solution to different problems that arise from this complexity

- simplified design (readily available, multi sourced components and tools)

- lower costs (less and smaller cables)
- improved reliability (fewer connections)
- analysis of problems improved (easy connection with a pc to read the data flowing through the cable).

4.2.4 Wirings: I/O connections

- After crimping the cable, verify that all strands are entrapped in the wire barrel.
- Verify that all the crimped contacts are completely inserted on the connector cavities.



A cable connected to the wrong pin can lead to short circuits and failure; so, before turning on the truck for the first time, verify with a multimeter the continuity between the starting point and the end of a signal wire.

- For information about the mating connector pin assignment see the paragraph “description of the connectors”.

4.2.5 Encoder installation

- 1) Dualac2 and Dualac2&hp card is fit for different types of encoder. To control AC motor with Zapi inverter, it is necessary to install an incremental encoder with 2 phases shifted of 90°. The encoder power supply can be +5 or +12V. It can have different electronic output.

C11/C1	+5V/+12V	positive of encoder power supply.
C12/C2	GND	negative of encoder power supply.
C22/C13	A	phase A of encoder.
C23/C14	B	phase B of encoder.

- 2) Connection of encoder with open collector output; +5V power supply.

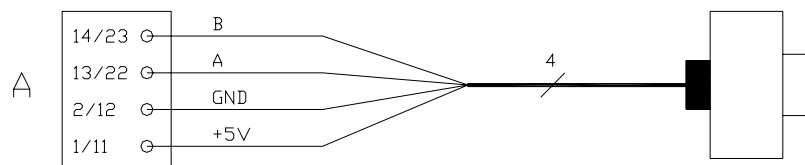

- 3) Connection of encoder with open collector output; +12V power supply.

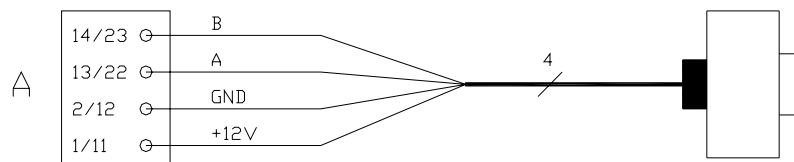

VERY IMPORTANT

It is necessary to specify in the order the type of encoder used, in terms of power supply, electronic output and n° of pulses for revolution, because

the logic unit must be set in the correct way by Zapi.

4.2.6 Main contactor and key connection

- The connection of the main contactor can be carried out following the drawing in the figure.

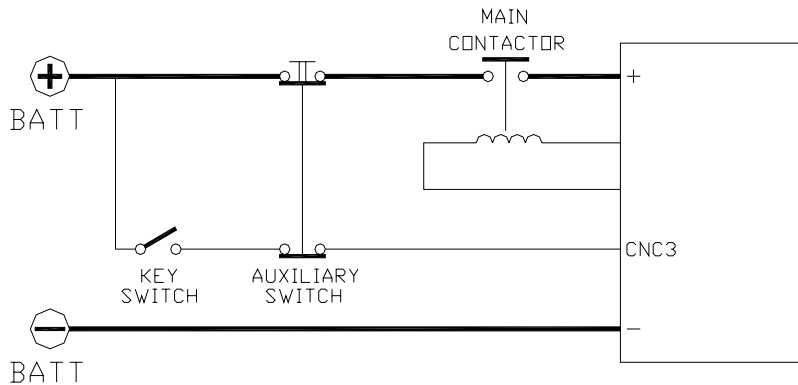

- The connection of the battery line switches must be carried out following ZAPI instructions.
- If a mechanical battery line switch is installed, it is necessary that the key supply to the inverter is open together with power battery line; if not, the inverter may be damaged if the switch is opened during a regenerative braking.
- An intrinsic protection is present inside the logic when the voltage on the battery power connection overtakes 40% more than the battery nominal voltage or if the key is switched off before the battery power line is disconnected.

4.2.7 Insulation of truck frame



As stated by EN-1175 “Safety of machinery – Industrial truck”, chapter 5.7, “there shall be no electrical connection to the truck frame”. So the truck frame has to be isolated from any electrical potential of the truck power line.

4.3 Protection and safety features

4.3.1 Protection features

- **Battery polarity inversion**
It is necessary to fit a MAIN CONTACTOR to protect the inverter against reverse battery polarity and for safety reasons.
- **Connection Errors:**
All inputs are protected against connection errors.
- **Thermal protection**
If the inverter temperature exceeds 75 °C, the maximum current is reduced in proportion to the thermal increase. The temperature can never exceed 100 °C.

- **External agents:**
The inverter is protected against dust and the spray of liquid to a degree of protection meeting IP65.
- **Protection against uncontrolled movements:**
The main contactor will not close if:
 - The Power unit is not functioning.
 - The Logic is not functioning perfectly.
 - The output voltage of the accelerator does not fall below the minimum voltage value stored, with 1 V added.
 - Running microswitch in closed position.
- **Low battery charge:**
When the battery charge is low, the maximum current is reduced to the half of the maximum current programmed.
- **Protection against accidental Start up**
A precise sequence of operations are necessary before the machine will start.
Operation cannot begin if these operations are not carried out correctly.
Requests for drive, must be made after closing the key switch.

4.3.2 Safety Features



ZAPI controllers are designed according to the prEN954-1 specifications for safety related parts of control system and to UNI EN1175-1 norm.



The safety of the machine is strongly related to installation; length, layout and screening of electrical connections have to be carefully designed. ZAPI is always available to cooperate with the customer in order to evaluate installation and connection solutions. Furthermore, ZAPI is available to develop new SW or HW solutions to improve the safety of the machine, according to customer requirements.
Machine manufacturer holds the responsibility for the truck safety features and related approval.

Dualac2 controller electronic implements double hardware circuit for four Digital inputs: Seat (C5), Forward (C6), Reverse (C7), Accelerator Enable (C8) and one Analog input: CPOT (C21).

These signals are input, through two independent hardware circuits, to both microcontrollers which implement a cross-check of the inputs status, thus preventing an abnormal behaviour due to a failure in the input hardware.

It is strongly suggested to connect the machine safety related devices to these five inputs, in order to increase machine safety.

4.4 EMC



EMC and ESD performances of an electronic system are strongly influenced by the installation. Special attention must be given to the lengths and the paths of the electric connections and the shields. This situation is beyond ZAPI's control. Zapi can offer assistance and suggestions, based on its years experience, on EMC related items. However, ZAPI declines any responsibility for non-compliance, malfunctions and failures, if correct testing is not made. The machine

manufacturer holds the responsibility to carry out machine validation, based on existing norms (EN12895 for industrial truck; EN50081-2 for other applications).

EMC stands for Electromagnetic Compatibility, and it represents the studies and the tests on the electromagnetic energy generated or received by an electrical device.

So the analysis works in two directions:

- 1) The study of the **emission** problems, the disturbances generated by the device and the possible countermeasure to prevent the propagation of that energy; we talk about “conduction” issues when guiding structures such as wires and cables are involved, “radiated emissions” issues when it is studied the propagation of electromagnetic energy through the open space. In our case the origin of the disturbances can be found inside the controller with the switching of the mosfets which are working at high frequency and generate RF energy, **but wires and cables have the key role to propagate the disturbs because they works as antennas**, so a good layout of the cables and their shielding can solve the majority of the emission problems.

- 2) The study of the **immunity** can be divided in two main branches: protection from electromagnetic fields and from electrostatic discharge. The **electromagnetic immunity** concern the susceptibility of the controller with regard to electromagnetic fields and their influence on the correct work made by the electronic device. There are well defined tests which the machine has to be exposed to. These tests are carried out at determined levels of electromagnetic fields, to simulate external undesired disturbances and verify the electronic devices response.

- 3) The second type of immunity, **ESD**, concerns the prevention of the effects of electric current due to excessive electric charge stored in an object. In fact, when a charge is created on a material and it remains there, it becomes an “electrostatic charge”; ESD happens when there is a rapid transfer from a charged object to another. This rapid transfer has, in turn, two important effects:
 - A) this rapid charge transfer can determine, by induction, disturbs on the signal wiring and thus create malfunctions; **this effect is particularly critical in modern machines, with serial communications (canbus) which are spread everywhere on the truck and which carry critical informations.**
 - B) in the worst case and when the amount of charge is very high, the discharge process can determine failures in the electronic devices; the type of failure can vary from an intermittently malfunction to a completely failure of the electronic device.

IMPORTANT NOTE: it is always much easier and cheaper to avoid ESD from being generated, than to increase the level of immunity of the electronic devices.

There are different solutions for EMC issues, depending on level of emissions/immunity required, the type of controller, materials and position of the wires and electronic components.

- 1) **EMISSIONS.** Three ways can be followed to reduce the emissions:

- A) **SOURCE OF EMISSIONS:** finding the main source of disturb and work on it.
 - B) **SHIELDING:** enclosing contactor and controller in a shielded box; using shielded cables;
 - C) **LAYOUT:** a good layout of the cables can minimize the antenna effect; cables running nearby the truck frame or in iron channels connected to truck frames is generally a suggested not expensive solution to reduce the emission level.
- 2) **ELECTROMAGNETIC IMMUNITY.** The considerations made for emissions are valid also for immunity. Additionally, further protection can be achieved with ferrite beads and bypass capacitors.
- 3) **ELECTROSTATIC IMMUNITY.** Three ways can be followed to prevent damages from ESD:
- A) **PREVENTION:** when handling ESD-sensitive electronic parts, ensure the operator is grounded; test grounding devices on a daily basis for correct functioning; this precaution is particularly important during controller handling in the storing and installation phase.
 - B) **ISOLATION:** use anti-static containers when transferring ESD-sensitive material.
 - C) **GROUNDING:** when a complete isolation cannot be achieved, a good grounding can divert the discharge current trough a “safe” path; the frame of a truck can works like a “local earth ground”, absorbing excess charge. **So it is strongly suggested to connect to truck frame all the parts of the truck which can be touched by the operator, who is most of the time the source of ESD.**

4.5 Various suggestions

- Never connect SCR low frequency chopper with ASYNCHRONOUS INVERTER because the ASYNCHRONOUS filter capacitors alter the SCR choppers' work. If it is necessary to use two or more control units (traction + lift. for ex.), they must belong to the ZAPIMOS family.
- During battery charge, disconnect ASYNCHRONOUS from the battery.

5 OPERATIONAL FEATURES

- Speed control.
- Optimum behaviour on a slope due to the speed feedback:
 - the motor speed follows the accelerator, starting a regenerative braking if the speed overtakes the speed set-point.
 - the system can perform an electrical stop on a ramp (the machine is electrically hold on a slope) for a programmable time (see also chapter 8.4).
- Stable speed in every position of the accelerator.
- Electronic differential feature with torque balance between external and internal wheel.
- Regenerative release braking based upon deceleration ramps.
- Regenerative braking when the accelerator pedal is partially released (deceleration).
- Direction inversion with regenerative braking based upon deceleration ramp.
- Regenerative braking and direction inversion without contactors: only the main contactor is present.
- The release braking ramp can be modulated by an analog input, so that a proportional brake feature is obtained.
- Optimum sensitivity at low speeds.
- Voltage boost at the start and with overload to obtain more torque (with current control).
- The inverter can drive an electromechanical brake.
- Hydraulic steering function:
 - the traction inverter sends a "hydraulic steering function" request to the pump inverter on the can-bus line.
 - moreover, if the pump inverter does not manage the steering function, because it is managed by a motor other than the main hydraulic motor, the traction inverter can manage an "hydraulic steering function" by driving a hydro contactor which drive a hydraulic steering motor (output C31).
- Backing forward and reverse options are available, with the tune and the speed of the function programmable with Zapi handset.
- High efficiency of motor and battery due to high frequency commutations.
- Modification of parameters through the programming console.
- Internal hour-meter with values that can be displayed on the console.
- Memory of the last five alarms with relative hour-meter and temperature displayed on the console.
- Diagnostic function with Zapi handset for checking main parameters.
- Built in BDI feature.
- Flash memory, sw downloadable via serial link and via CANBUS.
- Canopen interface available.

5.1 Diagnosis

The microcontrollers continually monitor the inverter and carry out a diagnostic procedure on the main functions. The diagnosis is made in 4 points.

- 1) Diagnosis on key switch closing that checks: watchdog circuit, current sensor, capacitor charging, phase's voltages, contactor drivers, can-bus interface, if the switch sequence for operation is correct and if the output of accelerator unit is correct, correct synchronization of the two μ CS, integrity of

safety related inputs hardware.

- 2) Standby diagnosis in stby that checks: watchdog circuit, phase's voltages, contactor driver, current sensor, can-bus interface.
- 3) Diagnosis during operation that checks: watchdog circuits, contactor driver, current sensors, can-bus interface.
- 4) Continuous diagnosis that checks: temperature of the inverter, motor temperature.

Diagnosis is provided in two ways. The digital console can be used, which gives a detailed information about the failure; the failure code is also sent on the Can-Bus.

6 DESCRIPTION OF THE CONNECTORS

6.1 Connectors of the logic - "Dualac2" and "Dualac2 Power"

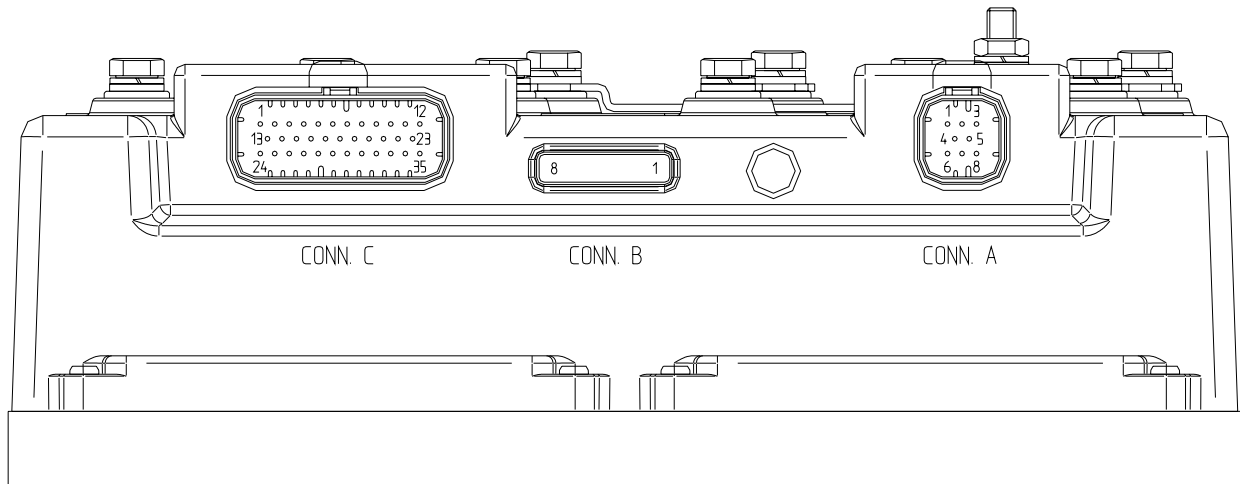

A1	CAN_H	High level CANBUS.
A2	CANT_H	CANBUS termination output, 120 ohm internally connected to CAN_H. Connect to CAN_L_OUT to insert the termination.
A3	CAN_POS	Positive of CAN circuit; to be used in case of optoisolated CANBUS.
A4	CAN_L_OUT	Low level CANBUS: to be used as repetition for CAN_L line or to be connected to CANT_H to insert termination resistance.
A5	CANT_L	CANBUS termination output, 120 ohm internally connected to CAN_L. Connect to CAN_H_OUT to insert the termination.
A6	CAN_L	Low level CANBUS.
A7	CAN_H_OUT	High level CANBUS: to be used as repetition for CAN_H line or to be connected to CANT_L to insert termination resistance.
A8	CAN_NEG	Negative of CAN circuit, to be used in case of optoisolated CANBUS.
B1	PCLRXD	Positive serial reception.
B2	NCLRXD	Negative serial reception.
B3	PCLTXD	Positive serial transmission.
B4	NCLTXD	Negative serial transmission.
B5	GND	Negative console power supply.
B6	+12	Positive console power supply.

B7	FLASH	
B8	FLASH	
C1	PENC_R	Positive of right motor encoder power supply (+5 V/+12 V).
C2	NENC_R	Negative of right motor encoder power supply.
C3	KEY	Connected to +Batt through a microswitch and a 10 A fuse in series.
C4	CM	Common of FW / REV / HB / PB / SEAT / ENABLE / SR / EX. HYDRO / BACKING microswitches.
C5	SEAT	Seat presence signal; active high.
C6	FORWARD	Forward direction request signal; active high.
C7	REVERSE	Reverse direction request signal; active high.
C8	ENABLE/BACK.	Traction or backing request signal; active high.
C9	PB	Pedal brake request signal; active high.
C10	SR/HB/EX. HYDRO	Speed reduction signal or hand brake or exclusive hydro input; active low (microswitch open). See also chapter 8.4.
C11	PENC_L	Positive of left motor encoder power supply (+5 V/+12 V).
C12	NENC_L	Negative of left motor encoder power supply.
C13	PHA_R	Right motor encoder phase A.
C14	PHB_R	Right motor encoder phase B.
C15	NPOTST	Negative of steering potentiometer (-BATT).
C16	PPOTST	Positive of steering potentiometer (+5 V/+12 V).
C17	CPOTST	Steering potentiometer wiper signal.
C18	CPOTB	Brake potentiometer wiper signal.
C19	NPOTB	-BATT.
C20	NPOT	Negative of traction accelerator potentiometer, tested for wire disconnection diagnosis.
C21	CPOT	Traction potentiometer wiper signal.
C22	PHA_L	Left motor encoder phase A.
C23	PHB_L	Left motor encoder phase B.
C24	NTHERM_R	Negative of right traction motor temperature sensor.
C25	PTHERM_R	Right traction motor temperature signal.
C26	NLC	Output of main contactor coil driver (drives to -BATT).
C27	PLC	Positive of main contactor coil.
C28	NBRAKE	Output of electric brake coil; drives the load to -BATT, maximum current 3 A.
C29	PBRAKE	Positive of the electromechanical brake coil.
C30	PAUX	Positive of auxiliary load.
C31	NAUX	Output of auxiliary load driver (drives to -BATT).
C32	-BATT	
C33	PPOT	Traction potentiometer positive, 5/10 V output; use

		load > 1 kohm.
C34	N THERM_L	Negative of left traction motor temperature sensor.
C35	P THERM_L	Left traction motor temperature signal.

6.2 Connectors of the logic - "Dualac2&hp" and "Dualac2&hp Power"

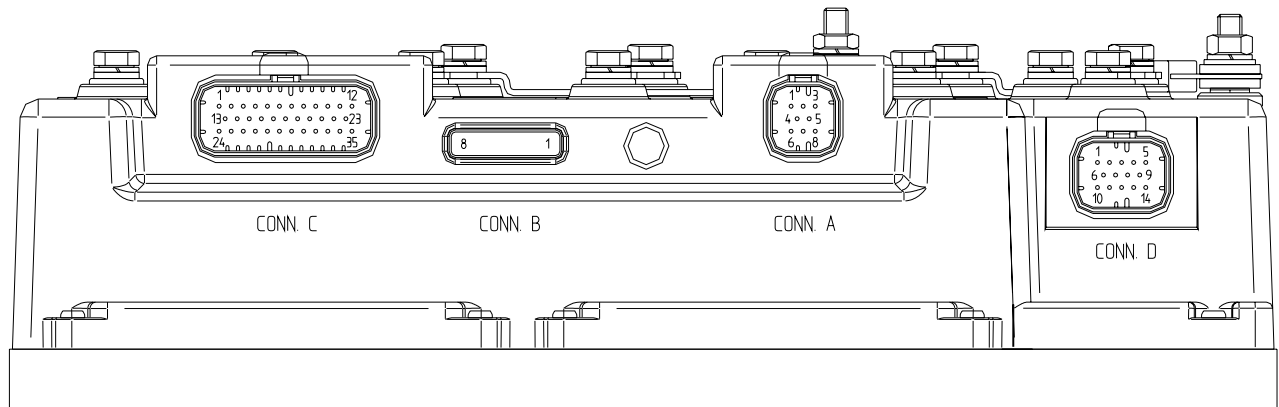

A1	CAN_H	High level CANBUS.
A2	CANT_H	CANBUS termination output, 120 ohm internally connected to CAN_H. Connect to CAN_L_OUT to insert the termination.
A3	CAN_POS	Positive of CAN circuit; to be used in case of optoisolated CANBUS.
A4	CAN_L_OUT	Low level CANBUS: to be used as repetition for CAN_L line or to be connected to CANT_H to insert termination resistance.
A5	CANT_L	CANBUS termination output, 120 ohm internally connected to CAN_L. Connect to CAN_H_OUT to insert the termination.
A6	CAN_L	Low level CANBUS.
A7	CAN_H_OUT	High level CANBUS: to be used as repetition for CAN_H line or to be connected to CANT_L to insert termination resistance.
A8	CAN_NEG	Negative of CAN circuit, to be used in case of optoisolated CANBUS.
B1	PCLRxD	Positive serial reception.
B2	NCLRxD	Negative serial reception.
B3	PCLTxD	Positive serial transmission.
B4	NCLTxD	Negative serial transmission.
B5	GND	Negative console power supply.

B6	+12	Positive console power supply.
B7	FLASH	
B8	FLASH	
C1	PENC_R	Positive of right motor encoder power supply (+5 V/+12 V).
C2	NENC_R	Negative of right motor encoder power supply.
C3	KEY	Connected to +Batt through a microswitch and a 10 A fuse in series.
C4	CM	Common of FW / REV / HB / PB / SEAT / ENABLE / SR / EX. HYDRO / BACKING microswitches.
C5	SEAT	Seat presence signal; active high.
C6	FORWARD	Forward direction request signal; active high.
C7	REVERSE	Reverse direction request signal; active high.
C8	ENABLE/BACK.	Traction or backing request signal; active high.
C9	PB	Pedal brake request signal; active high.
C10	SR/HB/EX. HYDRO	Speed reduction signal or hand brake or exclusive hydro input; active low (microswitch open). See also chapter 8.4.
C11	PENC_L	Positive of left motor encoder power supply (+5 V/+12 V).
C12	NENC_L	Negative of left motor encoder power supply.
C13	PHA_R	Right motor encoder phase A.
C14	PHB_R	Right motor encoder phase B.
C15	NPOTST	Negative of steering potentiometer (-BATT).
C16	PPOTST	Positive of steering potentiometer (+5 V/+12 V).
C17	CPOTST	Steering potentiometer wiper signal.
C18	CPOTB	Brake potentiometer wiper signal.
C19	NPOTB	-BATT.
C20	NPOT	Negative of traction accelerator potentiometer, tested for wire disconnection diagnosis.
C21	CPOT	Traction potentiometer wiper signal.
C22	PHA_L	Left motor encoder phase A.
C23	PHB_L	Left motor encoder phase B.
C24	NTHERM_R	Negative of right traction motor temperature sensor.
C25	PTHERM_R	Right traction motor temperature signal.
C26	NLC	Output of main contactor coil driver (drives to -BATT).
C27	PLC	Positive of main contactor coil.
C28	NBRAKE	Output of electric brake coil; drives the load to -BATT, maximum current 3 A.
C29	PBRAKE	Positive of the electromechanical brake coil.
C30	PAUX	Positive of auxiliary load.
C31	NAUX	Output of auxiliary load driver (drives to -BATT).
C32	-BATT	

C33	PPOT	Traction potentiometer positive, 5/10 V output; use load > 1 kohm.
C34	NTHERM_L	Negative of left traction motor temperature sensor.
C35	PTHERM_L	Left traction motor temperature signal.
D1	-BATT	Negative output.
D2	2ND	Second hydraulic speed input, active high.
D3	1ST	First hydraulic speed input, active high.
D4	ENABLE	Input for proportional lifting enable; active high.
D5	CMM	Common output of microswitches (+BATT).
D6	5TH	Fifth hydraulic speed input, active high.
D7	4TH	Fourth hydraulic speed input, active high.
D8	3RD	Third hydraulic speed input, active high.
D9	CPOTLIFT	Input for proportional lift potentiometer.
D10	-BATT	
D11	-BATT	
D12	-BATT	
D13	NPOTLIFT	Negative for proportional lift potentiometer.
D14	PPOTLIFT	Positive for proportional lift potentiometer (12 V).

6.3 CANBUS connector description

Dualac2 Controller has a canbus interface, so it has been designed to work in a can network together with other electronic modules, exchanging information over the canbus network.

Furthermore, the exchange of information between master and slave microcontrollers is based on the canbus, as well.

Dualac2 also provides built-in can termination resistance, which can be connected in different ways, as described here following:

6.3.1 "Dualac2" Controller in stand-alone configuration

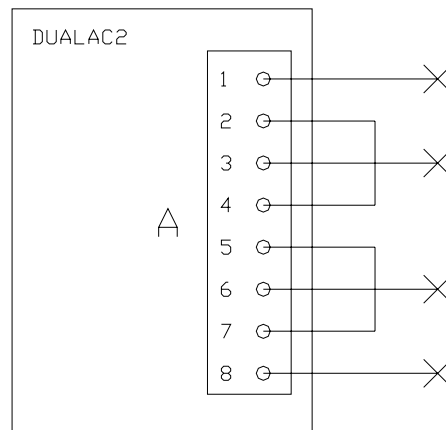

Bridge 2-4 and 5-7 connect both built-in 120 ohm can termination resistances.

6.3.2 "Dualac2" Controller is a termination module in the canbus net

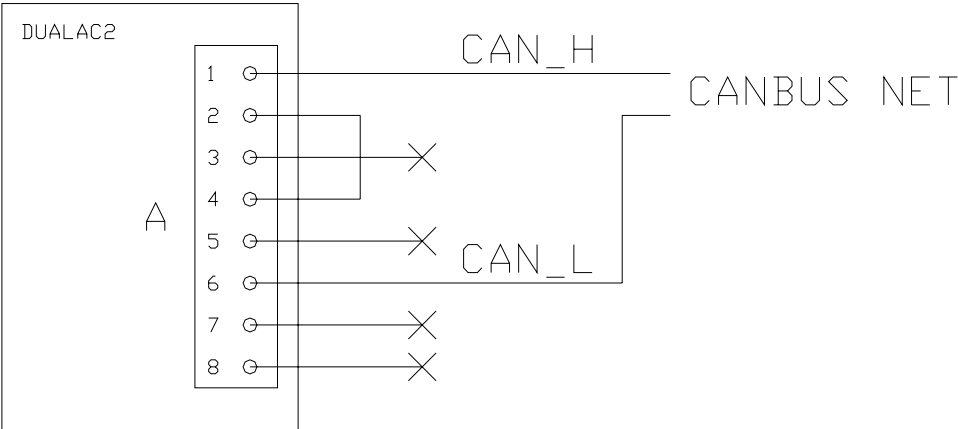

Bridge 2-4 connects one built-in 120 ohm can termination resistance, the second will be connected in another module of the canbus net.

6.3.3 "Dualac2" Controller is a repetition module in the canbus net

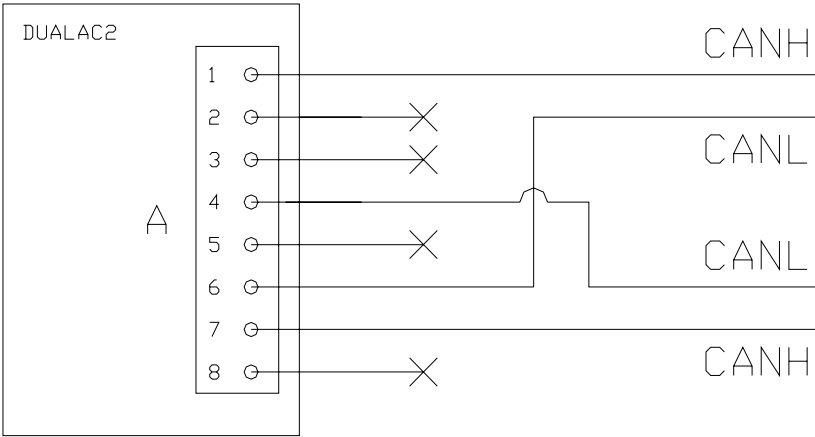

The canbus built-in termination resistances are not inserted.

6.4 Description of power connections

6.4.1 "Dualac2"

View of the power bars:

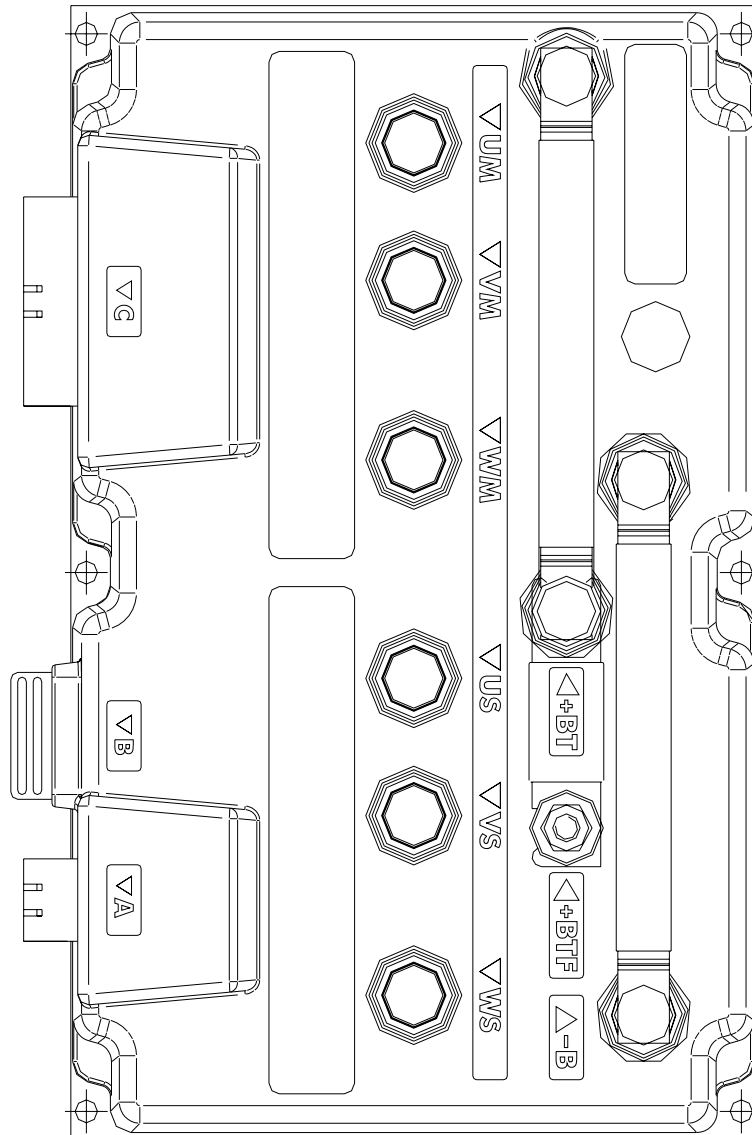

-B	Negative of the battery.
+BT	Positive of the battery; if the power fuse is not present, the positive cable coming from LC contact must be connected to this power connection.
+BTF	Positive of battery before power fuse, must be connected to positive cable coming from LC contact.
Um; Vm; Wm	Connection bars of the three right motors phases; follow this sequence and the indication on the motor.
Us; Vs; Ws	Connection bars of the three left motors phases; follow this sequence and the indication on the motor.

6.4.2 "Dualac2 Power"

View of the power bars:

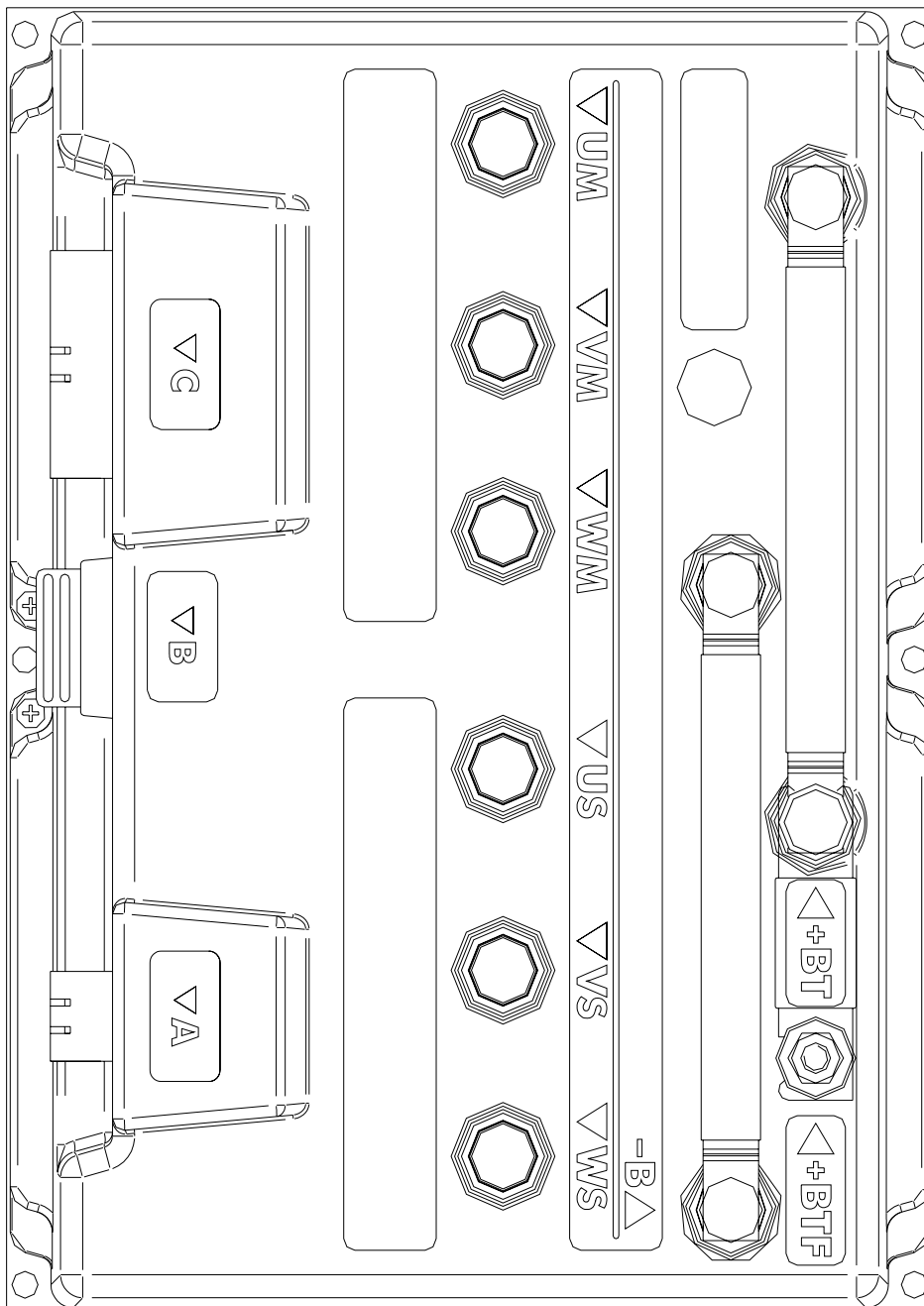

-B	Negative of the battery.
+BT	Positive of the battery; if the power fuse is not present, the positive cable coming from LC contact must be connected to this power connection.
+BTF	Positive of battery before power fuse, must be connected to positive cable coming from LC contact.
Um; Vm; Wm	Connection bars of the three right motors phases; follow this sequence and the indication on the motor.
Us; Vs; Ws	Connection bars of the three left motors phases; follow this sequence and the indication on the motor.

6.4.3 "Dualac2&hp"

View of the power bars:

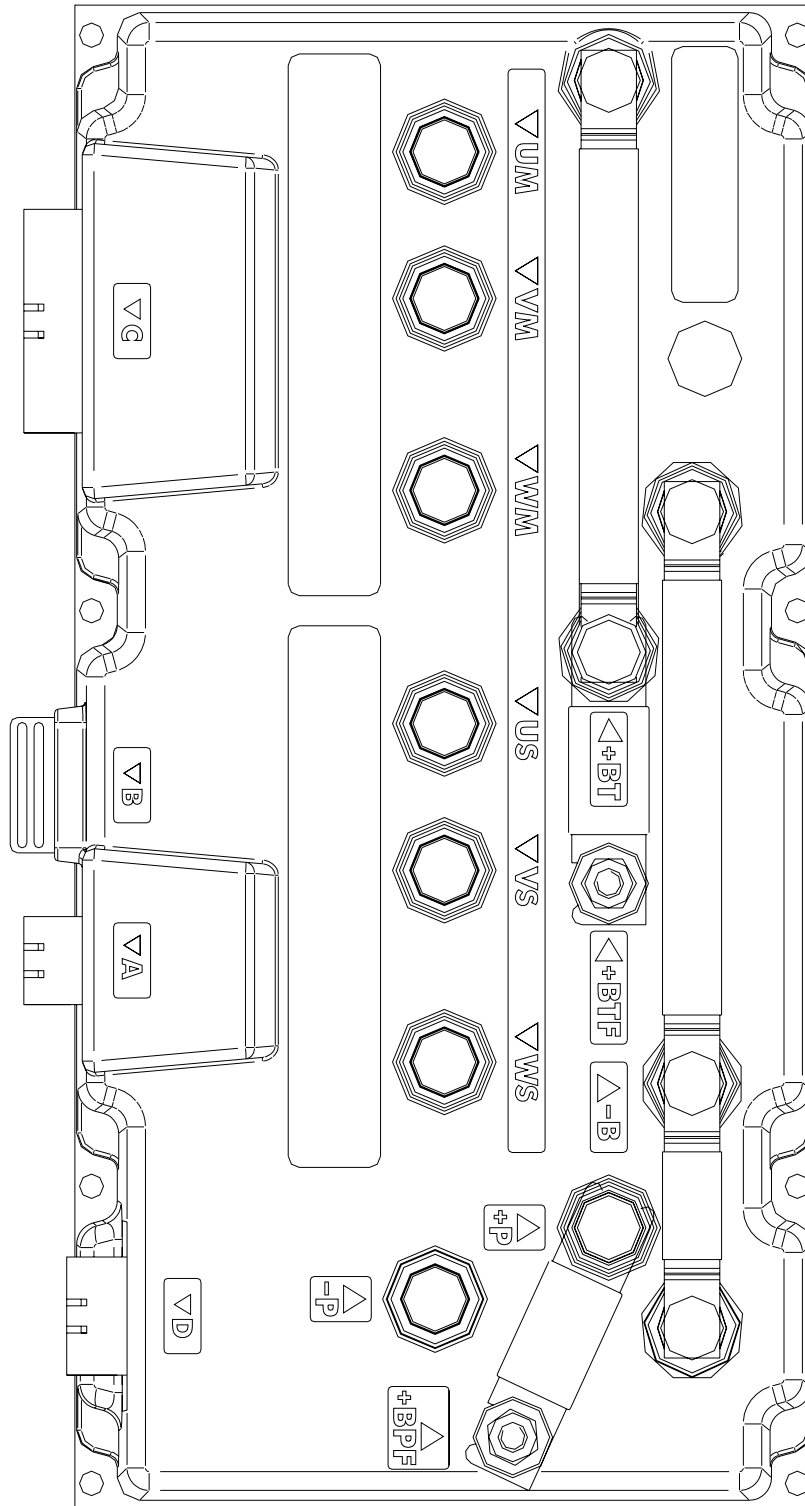

-B
+BT

Negative of the battery.

Positive of the battery; if the power fuse is not present, the positive cable coming from LC contact must be connected to this power connection.

+BTF	Positive of battery before power fuse, must be connected to positive cable coming from LC contact.
Um; Vm; Wm	Connection bars of the three right motors phases; follow this sequence and the indication on the motor.
Us; Vs; Ws	Connection bars of the three left motors phases; follow this sequence and the indication on the motor.
-P	Output of pump motor chopper.
+P	Pump chopper positive, if the power fuse is not present, the positive cable coming from LC contact must be connected to this power connection; also the pump motor positive cable must be connected to this power connection.
+BPF	Pump chopper positive before power fuse, must be connected to positive cable coming from LC contact.

6.4.4 "Dualac2&hp Power"

View of the power bars:

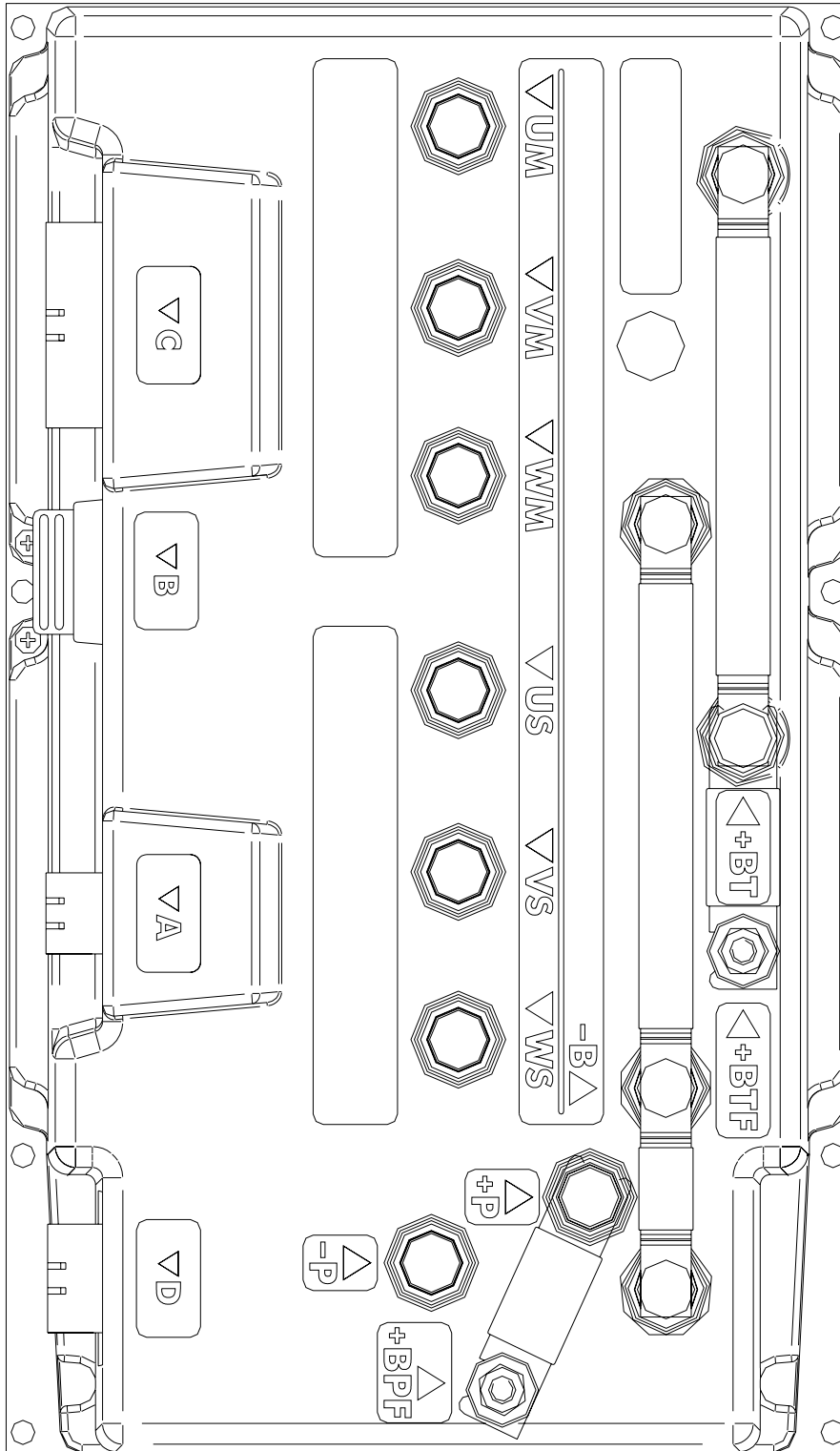

-B

Negative of the battery.

+BT

Positive of the battery; if the power fuse is not present, the positive cable coming from LC contact must be connected to this power connection.

+BTF	Positive of battery before power fuse, must be connected to positive cable coming from LC contact.
Um; Vm; Wm	Connection bars of the three right motors phases; follow this sequence and the indication on the motor.
Us; Vs; Ws	Connection bars of the three left motors phases; follow this sequence and the indication on the motor.
-P	Output of pump motor chopper.
+P	Pump chopper positive, if the power fuse is not present, the positive cable coming from LC contact must be connected to this power connection; also the pump motor positive cable must be connected to this power connection.
+BPF	Pump chopper positive before power fuse, must be connected to positive cable coming from LC contact.

7 DRAWINGS

7.1 Mechanical drawing

7.1.1 Dimensions of "Dualac2"

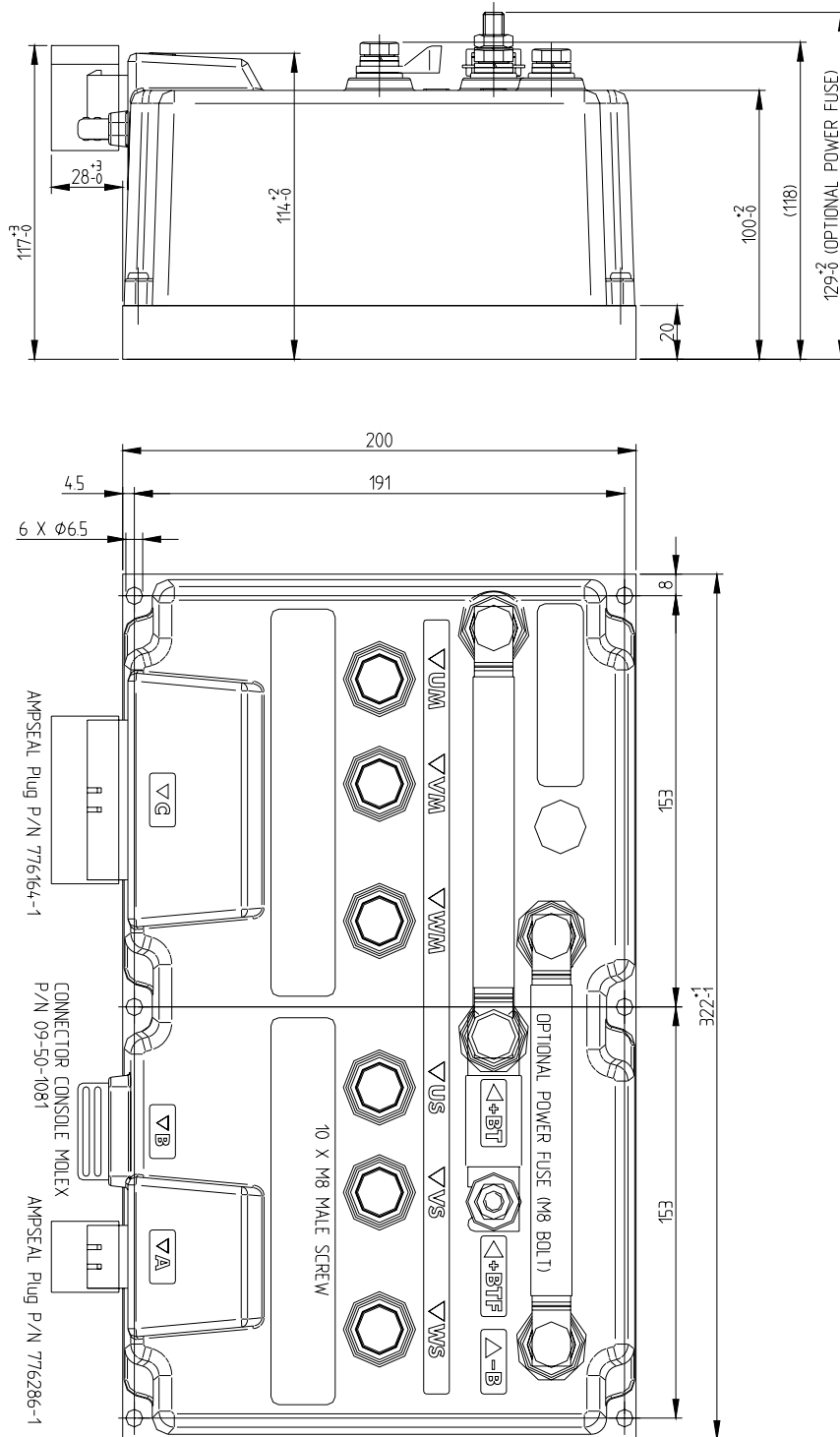

7.1.2 Dimensions of "Dualac2 Power"

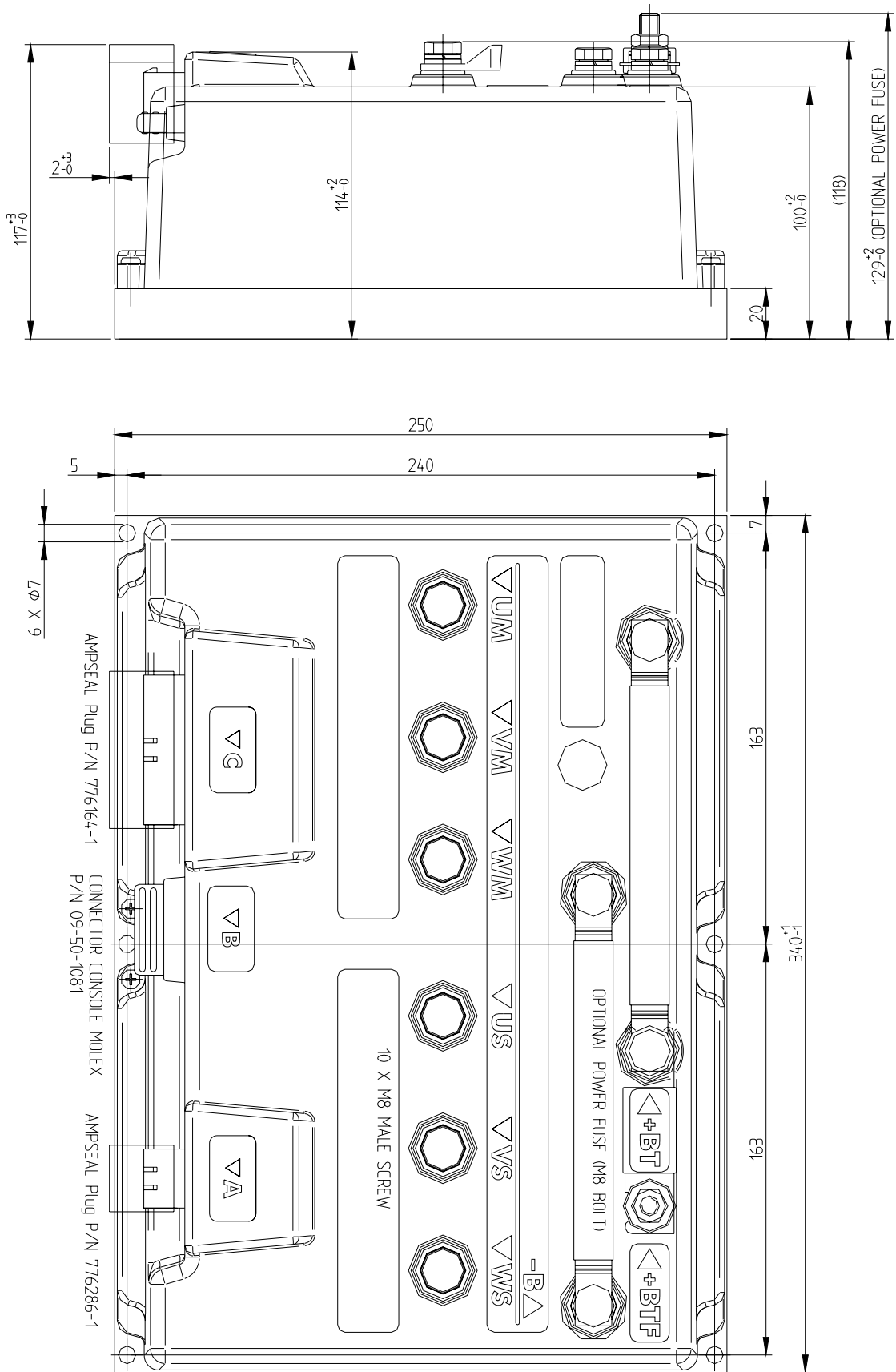

7.1.3 Dimensions of "Dualac2&hp"

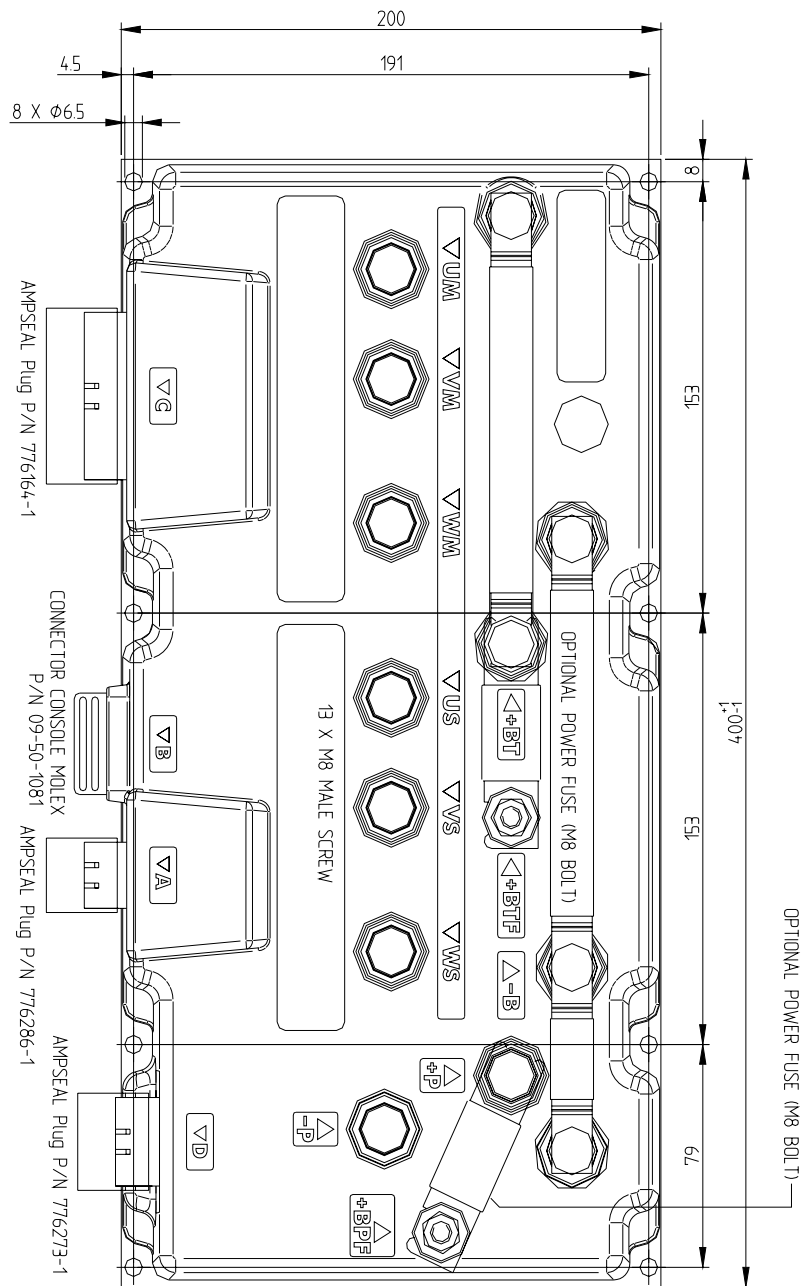
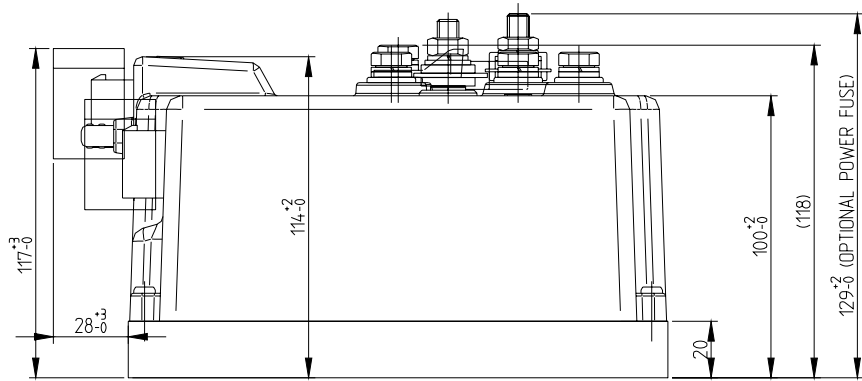

7.1.4 Dimensions of "Dualac2&hp Power"

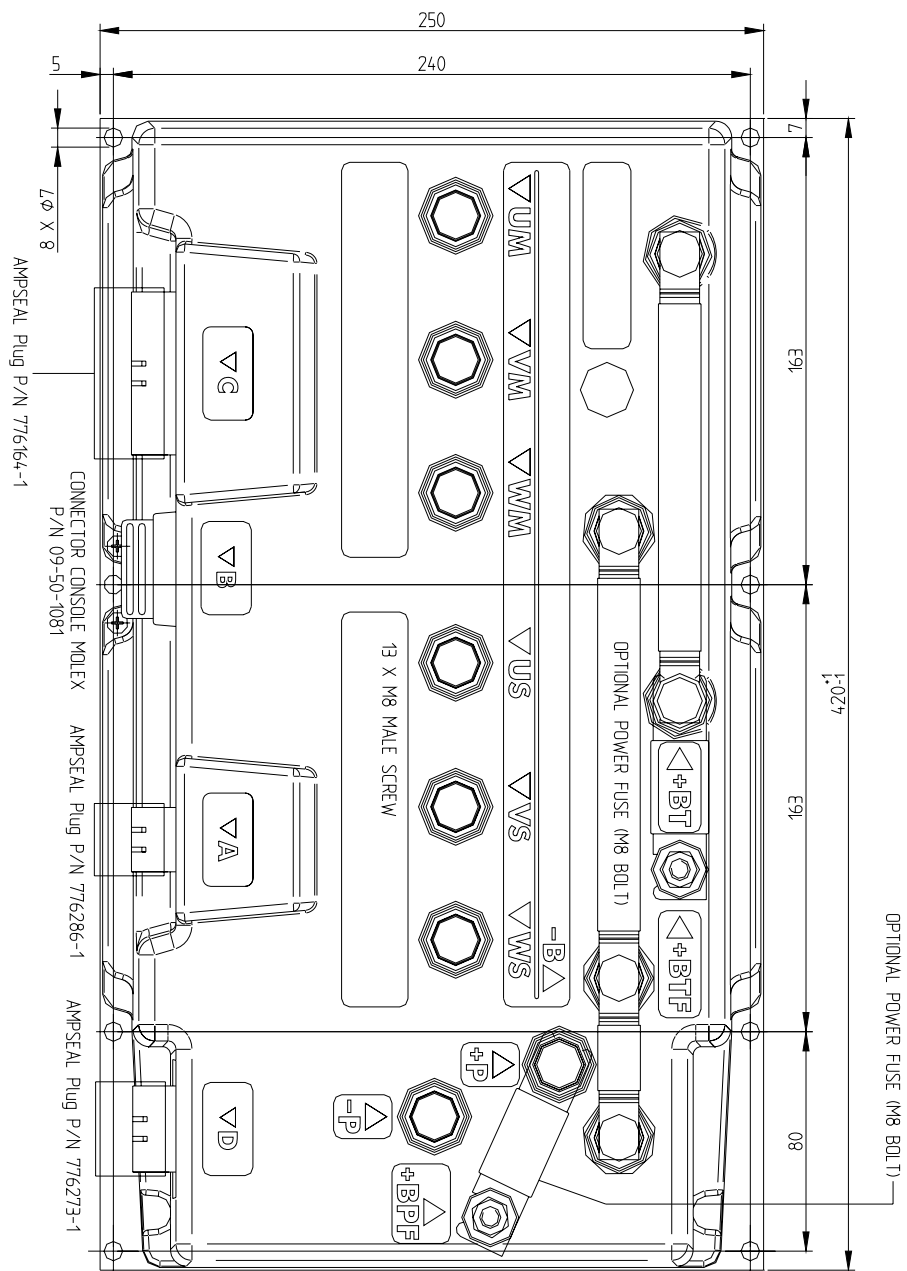
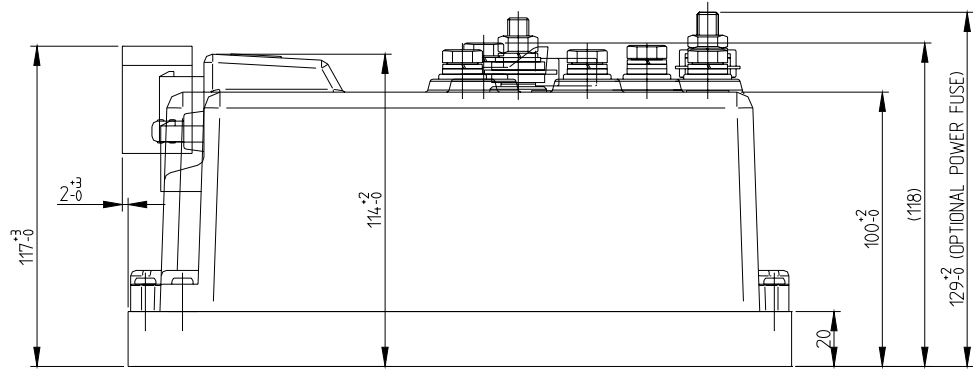

7.2 Connection drawing - "Dualac2" and "Dualac2 Power" standalone

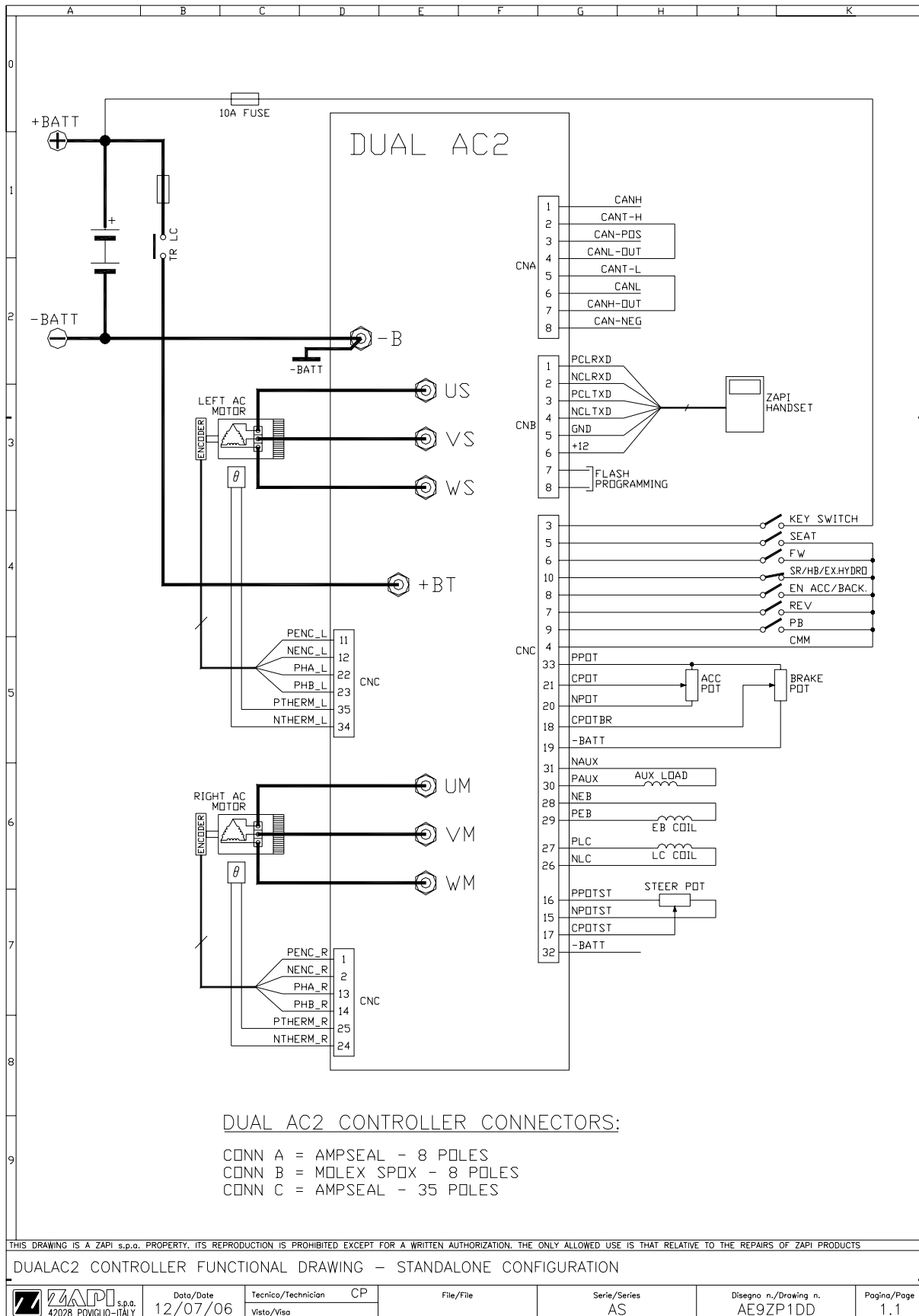

7.3 Connection drawing - "Dualac2&hp" and "Dualac2&hp Power" standalone

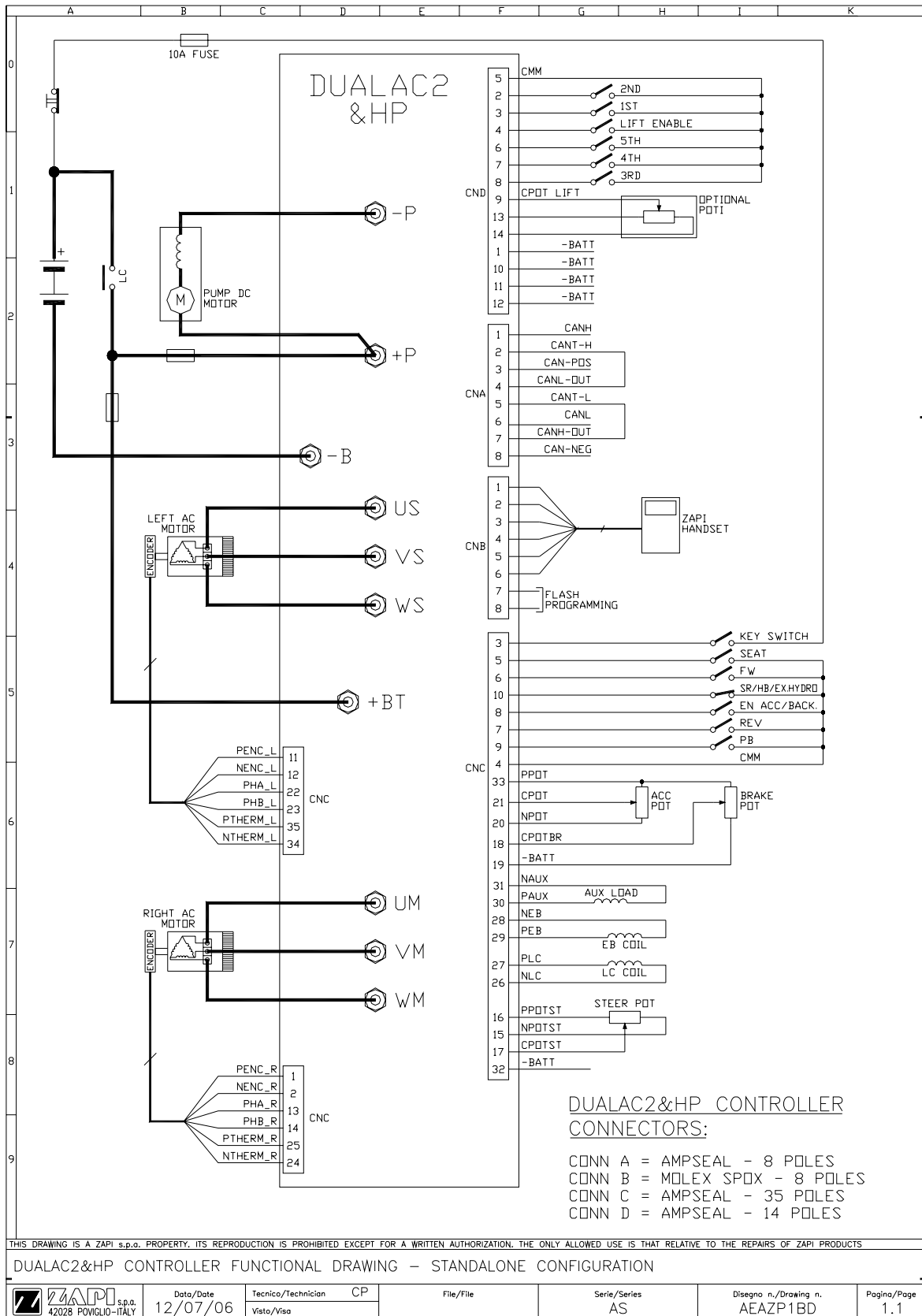

8 PROGRAMMING & ADJUSTMENTS USING DIGITAL CONSOLE

8.1 Adjustments via Console

Adjustment of Parameters and changes to the inverter's configuration are made using the Digital Console. The Console is connected to the "B" connector of the inverter.

8.2 Description of Console & Connection

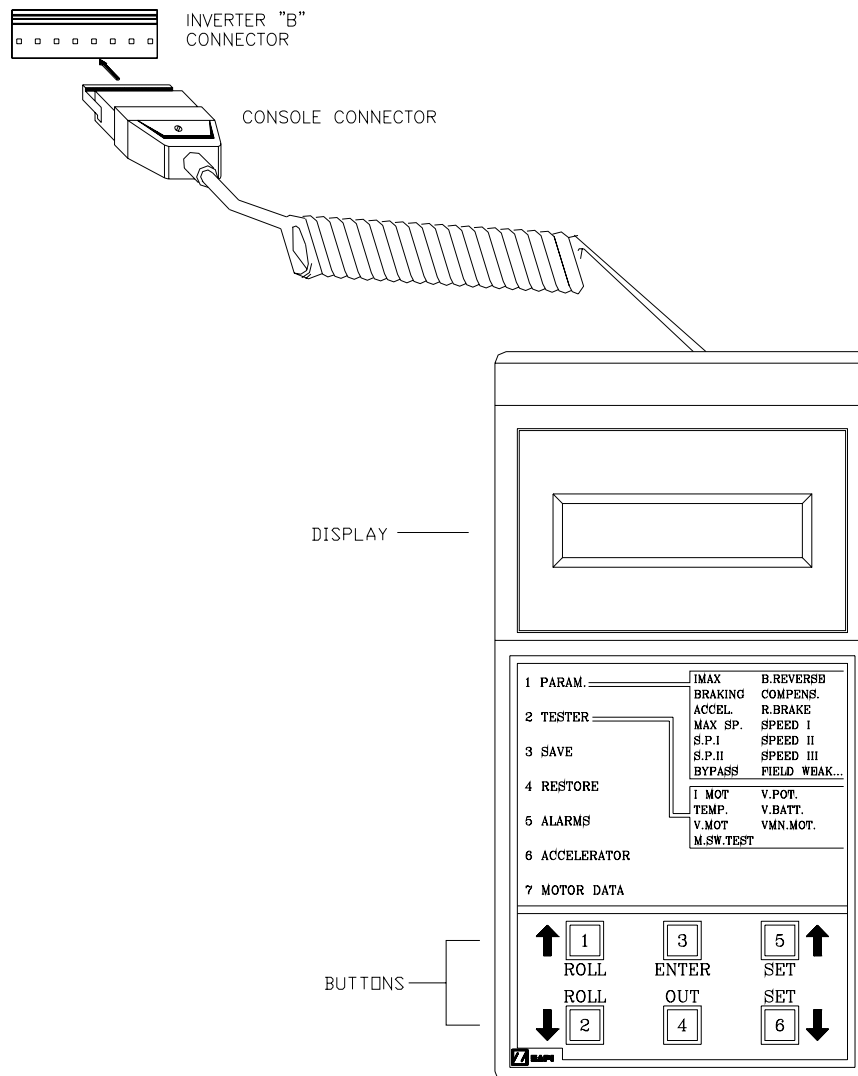

Digital consoles used to communicate with AC inverter controllers must be fitted with EPROM CK ULTRA, minimum "Release Number 3.02".

8.3 Description of Standard Console Menu

8.3.1 "Dualac2" and "Dualac2 Power" menu configuration

8.3.1.a Master

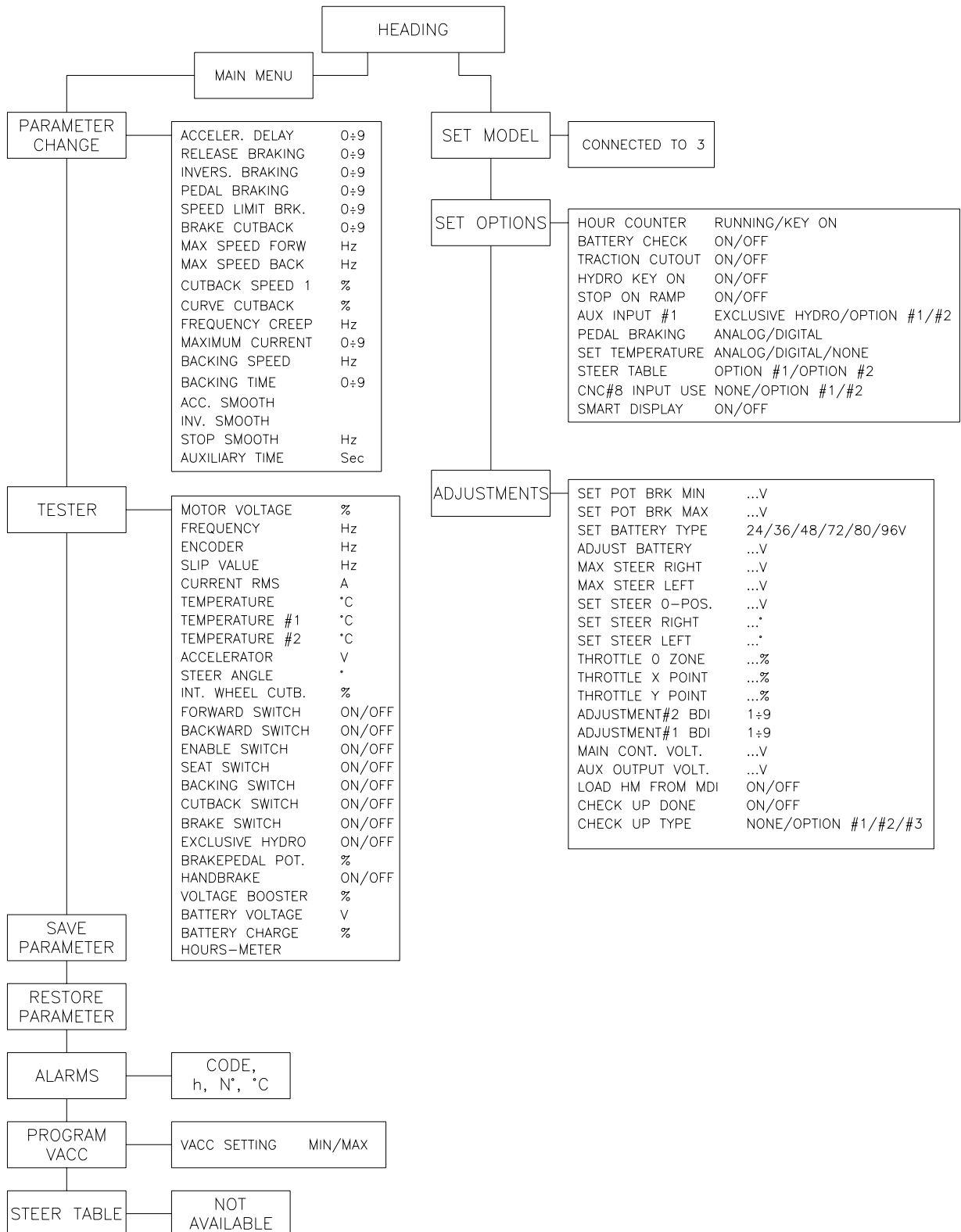

8.3.1.b Slave

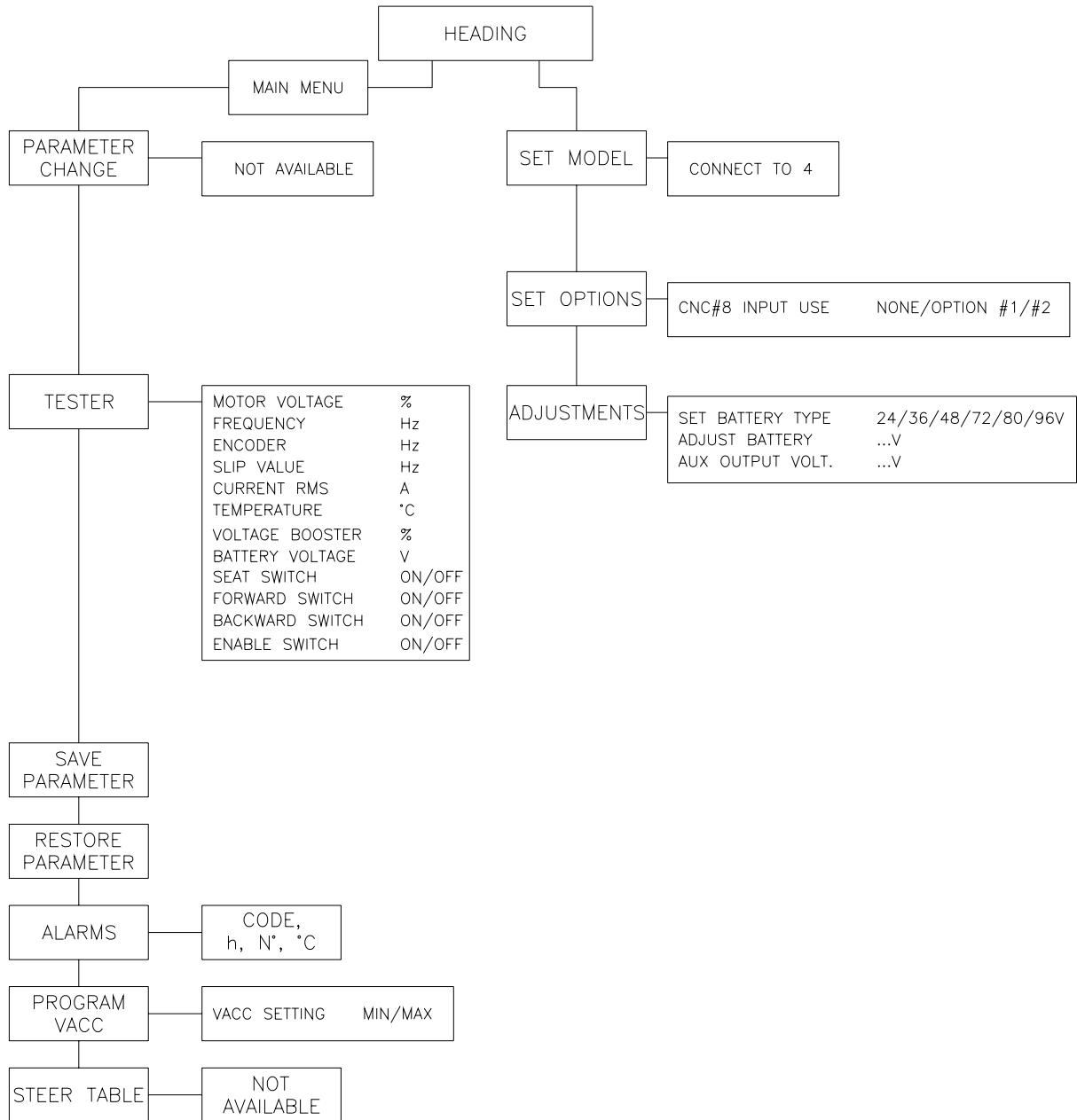

8.3.2 "Dualac2&hp" and "Dualac2&hp Power" menu configuration

8.3.2.a Master

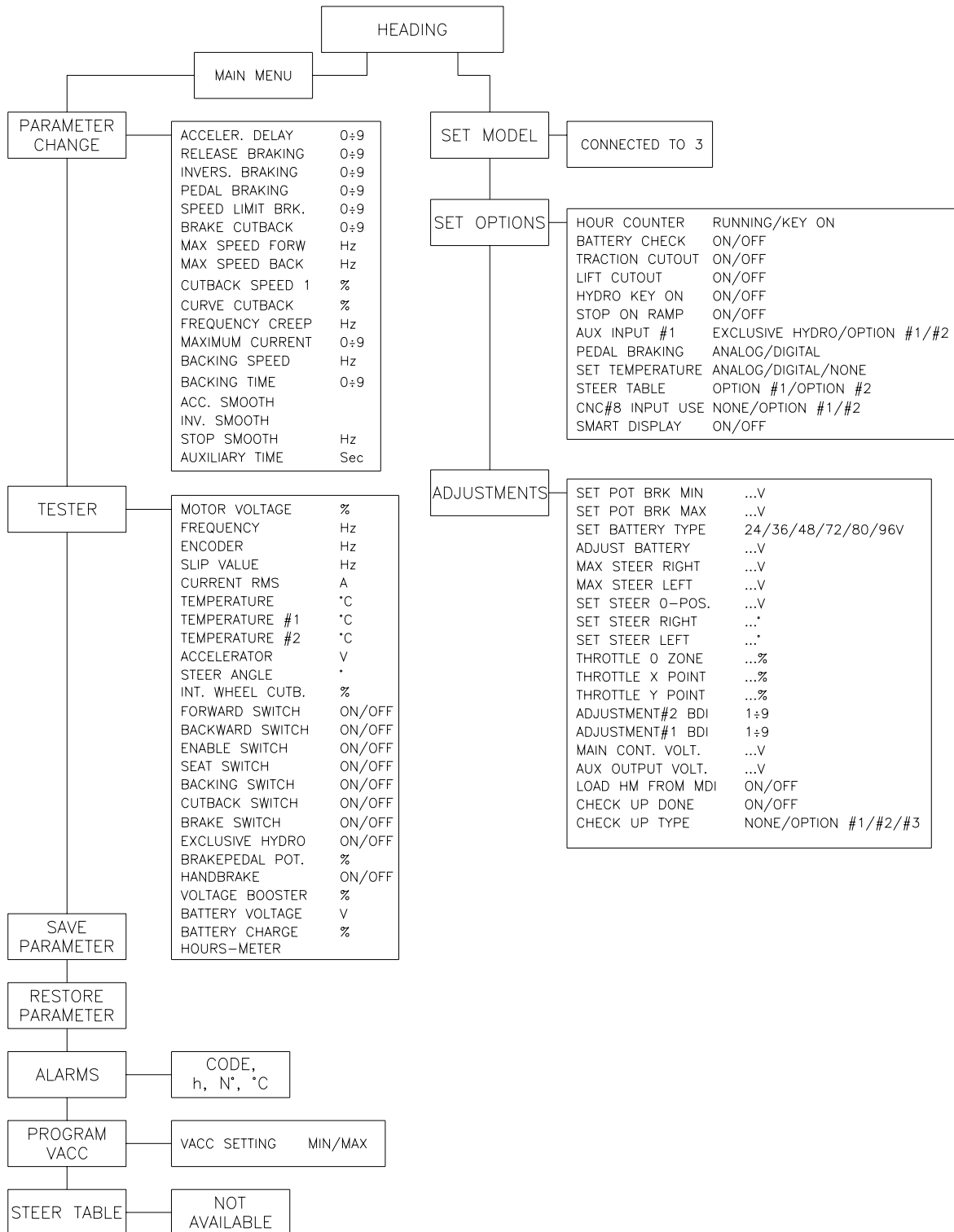

8.3.2.b Slave

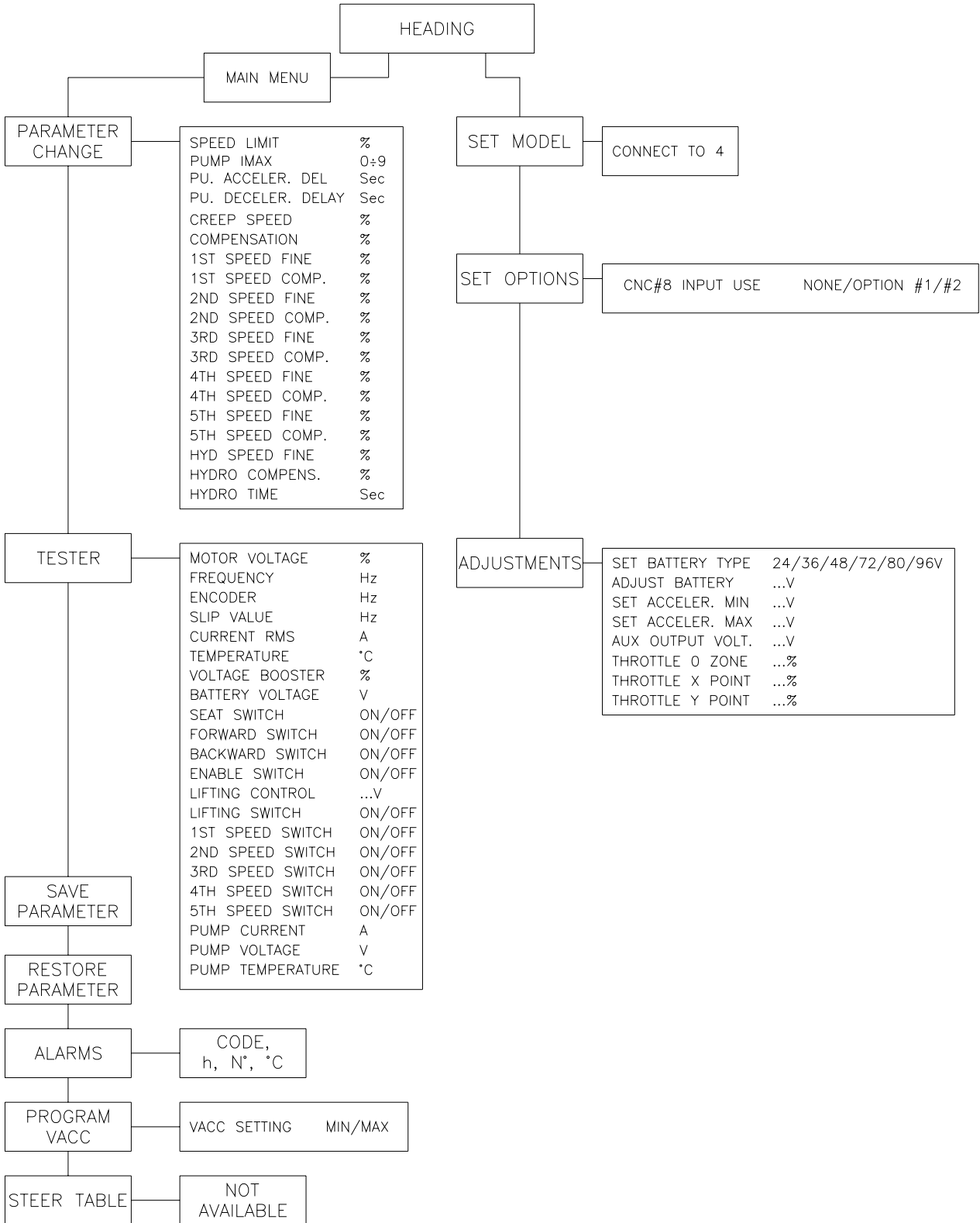

8.4 Function configuration

8.4.1 "Dualac2" and "Dualac2 Power" - Master

Using the CONFIG MENU of the programming console, the user can configure the following functions (see "OPERATIONAL FEATURE" chapter for an explanation of "hydraulic steering function"):

SUBMENU "SET OPTIONS"

1) HOUR COUNTER

- RUNNING: the counter registers travel time only.
- KEY ON: the counter registers when the "key" switch is closed.

2) BATTERY CHECK

- ON: the battery discharge level check is carried out; when the battery level reaches 10%, an alarm is signalled and the maximum current is reduced to the half of the programmed value.
- OFF: the battery discharge level check is carried out but no alarm is signalled.

3) TRACTION CUTOUT

- ON / OFF: when the "Battery low" alarm appears, if this option is programmed ON the traction speed is reduced to 60 Hz.

4) HYDRO KEY ON

- ON / OFF: if this option is programmed ON the traction inverter manages an hydraulic steering function when the "key" is switched ON.

5) STOP ON RAMP

- ON: the stop on ramp feature (truck electrically hold on a ramp) is managed for a time established by "auxiliary time" parameter.
- OFF: the stop on ramp feature is not performed.

6) AUX INPUT #1

- EXCLUSIVE HYDRO: input C10 activates hydraulic steering function, output C31 is activated.
- OPTION #1: input C10 is the input for an handbrake device, active low (open switch).
- OPTION #2: input C10 is the input for a speed reduction device, active low (open switch).

7) PEDAL BRAKING

- ANALOG: the mechanical brake pedal has a switch and a potentiometer installed. When the accelerator is released and the pedal brake is pushed the inverter performs an electrical braking whose intensity is proportional to the brake pedal potentiometer. The minimum intensity is established by the "Release braking" parameter, when the brake pedal is slightly pressed (brake switch close but brake potentiometer at the minimum). The maximum intensity is established by the "Pedal braking" parameter when the brake pedal is fully pressed (brake potentiometer at the maximum). In the middle positions, the electrical braking intensity is a linear function between minimum and maximum intensity.
- DIGITAL: the truck does not have a potentiometer installed on the mechanical brake pedal, but only a microswitch; when the accelerator pedal is released and the brake pedal is pushed (brake switch closed), the inverter performs an electrical braking following "Pedal braking" parameter.

8) SET TEMPERATURE

- DIGITAL: a digital (ON/OFF) motor thermal sensor is connected to C25 (C35) input.
- ANALOG: an analog motor thermal sensor is connected to C25 (C35) (the curve can be customized on a customer request).
- NONE: no motor thermal sensor switch is connected.

9) STEER TABLE

This parameter is used to set the correct steering table.

10) CNC#8 INPUT USE

- OPTION #1: input C8 is used as enable input for the traction request, active high (closed switch).
- OPTION #2: input C8 activates backing function, active high (closed switch).
- NONE: input C8 isn't used.

11) SMART DISPLAY

- ON / OFF: if this option is programmed ON the communication with the Smart display is active.

SUBMENU "ADJUSTMENTS"

1) SET POT BRK MIN

It records the minimum value of braking pedal potentiometer when the braking pedal switch is closed; the procedure is similar to the "Program Vacc" function (see chapter 9.3). This procedure must be carried out only if the "Pedal braking" option is programmed as "Analog".

2) SET POT BRK MAX

It records the maximum value of braking pedal potentiometer when the braking pedal is fully pressed; the procedure is similar to the "Program Vacc" function (see chapter 9.3). This procedure must be carried out only if the "Pedal braking" option is programmed as "Analog".

3) SET BATTERY TYPE

It selects the nominal battery voltage.

4) ADJUST BATTERY

Fine adjustment of the battery voltage measured by the controller.

5) MAX STEER RIGHT

This is the function to record in the controller EEPROM the steering poti output voltage when the wheels are fully turned right (maximum of the steering poti range).

6) MAX STEER LEFT

This is the function to record in the controller EEPROM the steering poti output voltage when the wheels are fully turned left (minimum of the steering poti range).

7) SET STEER 0-POS.

This is the function to record in the controller EEPROM the steering poti output voltage when the wheels are straight.

8) SET STEER RIGHT

This parameter sets the max steering angle in right direction.

9) SET STEER LEFT

This parameter sets the max steering angle in left direction.

10) THROTTLE 0 ZONE

It establishes a deadband in the accelerator input curve (see also curve below).

11) THROTTLE X POINT

This parameter changes the characteristic of the accelerator input curve.

12) THROTTLE Y POINT

This parameter changes the characteristic of the accelerator input curve.

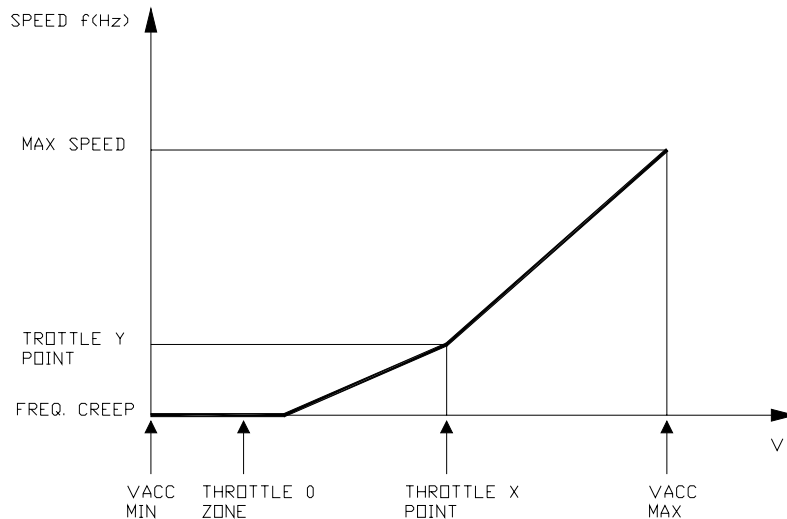

VACC MIN and VACC MAX are values programmable by the "Program Vacc" function.

13) ADJUSTMENT#1 BDI

It adjusts the upper level of the battery discharge table.

14) ADJUSTMENT#2 BDI

It adjusts the lower level of the battery discharge table.

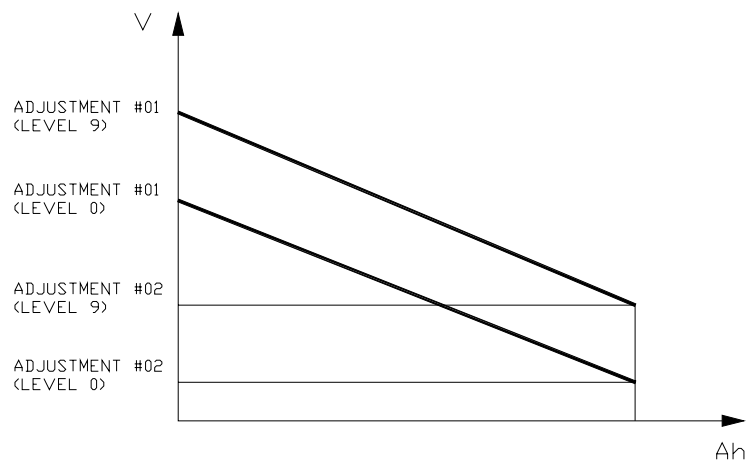

15) MAIN CONT. VOLTAGE

This parameters adjusts the Line contactor coil voltage (PWM output C26).

16) AUX OUTPUT VOLTAGE

This parameters adjusts the Electric brake coil voltage (PWM output C28).

17) LOAD HM FROM MDI

When set On, the HourMeter of the Controller is transferred and recorded on the HourMeter of the Standard MDI (connected on the Serial Link).

18) CHECK UP DONE

Turn it ON when the required Maintenance service has been executed to cancel the CHECK UP NEEDED warning.

19) CHECK UP TYPE

It specifies the handling of the CHECK UP NEEDED warning:

- NONE: No CHECK UP NEEDED warning.
- OPTION #1: CHECK UP NEEDED warning shown on the hand set and MDI after 300 hours.
- OPTION #2: Equal to OPTION#1 but speed reduction after 340 hours.

- OPTION #3: Equal to OPTION#2 but the truck definitively stops after 380 hours.

8.4.2 "Dualac2" and "Dualac2 Power" - Slave

Using the config menu of the programming console, the user can configure the following functions.

SUBMENU "SET OPTIONS"

1) CNC#8 INPUT USE

- OPTION #1: input C8 is used as enable input for the traction request, active high (closed switch).
- OPTION #2: input C8 activates backing function, active high (closed switch).
- NONE: input C8 isn't used.

SUBMENU "ADJUSTMENTS"

1) SET BATTERY TYPE

It selects the nominal battery voltage.

2) ADJUST BATTERY

Fine adjustment of the battery voltage measured by the controller.

3) AUX OUTPUT VOLTAGE

This parameter adjusts the voltage of the auxiliary output coil (hydraulic steering contactor coil), PWM output C31.

8.4.3 "Dualac2&hp" and "Dualac2&hp Power" - Master

There are the same functions described in chapter 8.4.1, but in the "SET OPTIONS" SUBMENU there is also the following parameter.

1) LIFT CUTOUT

- ON / OFF: when the "Battery low" alarm appears, if this option is programmed ON the lifting is stopped.

8.4.4 "Dualac2&hp" and "Dualac2&hp Power" - Slave

Using the config menu of the programming console, the user can configure the following functions.

SUBMENU "SET OPTIONS"

1) CNC#8 INPUT USE

- OPTION #1: input C8 is used as enable input for the traction request, active high (closed switch).
- OPTION #2: input C8 activates backing function, active high (closed switch).
- NONE: input C8 isn't used.

SUBMENU "ADJUSTMENTS"

1) SET BATTERY TYPE

It selects the nominal battery voltage.

2) ADJUST BATTERY

Fine adjustment of the battery voltage measured by the controller.

3) SET ACCELER. MIN

This parameter is used to adjust minimum value of the lift potentiometer. Press ENTER, pull the lever till the lift switch closes, then record the value (OUT --> ENTER).

4) SET ACCELER. MAX

This parameter is used to adjust maximum value of the lift potentiometer. Press ENTER, pull the lever to the maximum, then record the value (OUT -->

ENTER).

5) AUX OUTPUT VOLTAGE

This parameter adjusts the voltage of the auxiliary output coil (hydraulic steering contactor coil), PWM output C31.

6) THROTTLE 0 ZONE

It establishes a deadband in the lifting accelerator input curve (see also curve below).

7) THROTTLE X POINT

This parameter changes the characteristic of the lifting accelerator input curve.

8) THROTTLE Y POINT

This parameter changes the characteristic of the lifting accelerator input curve.

Flow chart showing how to make changes to OPTIONS Menu.

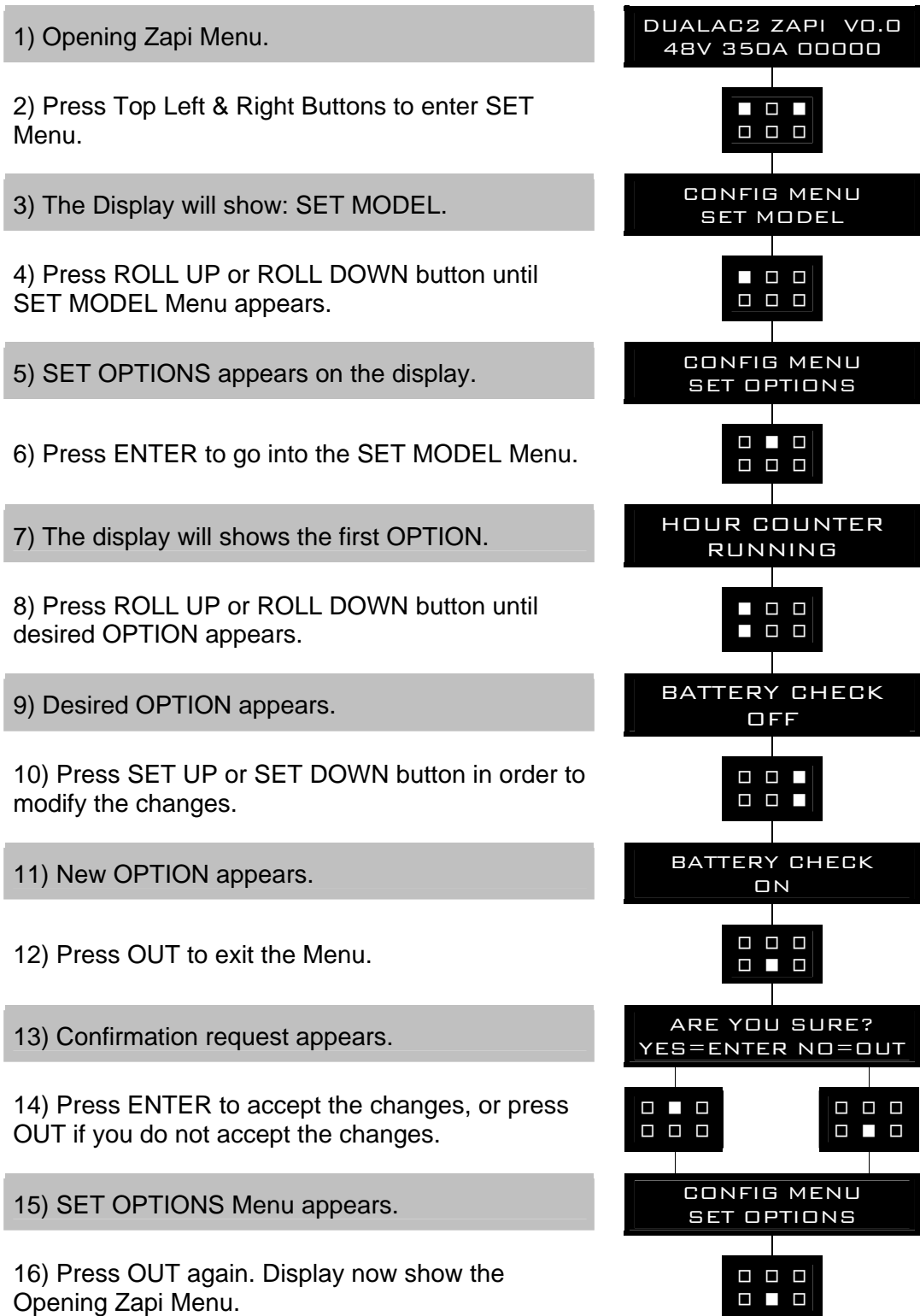

Flow chart showing how to make changes to ADJUSTMENTS Menu.

1) Opening Zapi Menu.

DUALAC2 ZAPI V0.0
48V 350A 00000

2) Press Top Left & Right Buttons to enter CONFIG Menu.

■ □ ■
□ □ □

3) The display will show: SET MODEL.

CONFIG MENU
SET MODEL

4) Press ROLL UP or ROLL DOWN button until ADJUSTMENTS Menu appears.

■ □ □
□ □ □

5) ADJUSTMENTS appears on the display.

CONFIG MENU
ADJUSTMENTS

6) Press ENTER to go into the ADJUSTMENTS Menu.

□ ■ □
□ □ □

7) The display will shows SET POT BRK MIN.

SET POT BRK MIN
0.0V

8) Press ROLL UP or ROLL DOWN button until the desired parameter is reached.

■ □ □
■ □ □

9) The desired parameter appears.

TROTTLER ZONE
3%

10) Press SET UP or SET DOWN button to modify the adjustment

□ □ ■
□ □ ■

TROTTLER ZONE
7%

11) Press OUT.

□ □ □
□ ■ □

12) Press ENTER to confirm.

□ ■ □
□ □ □

13) Repeat the same from 5 to 12 points for the other adjustments.

Flow chart showing how to use the SET BATTERY TYPE adjustment.

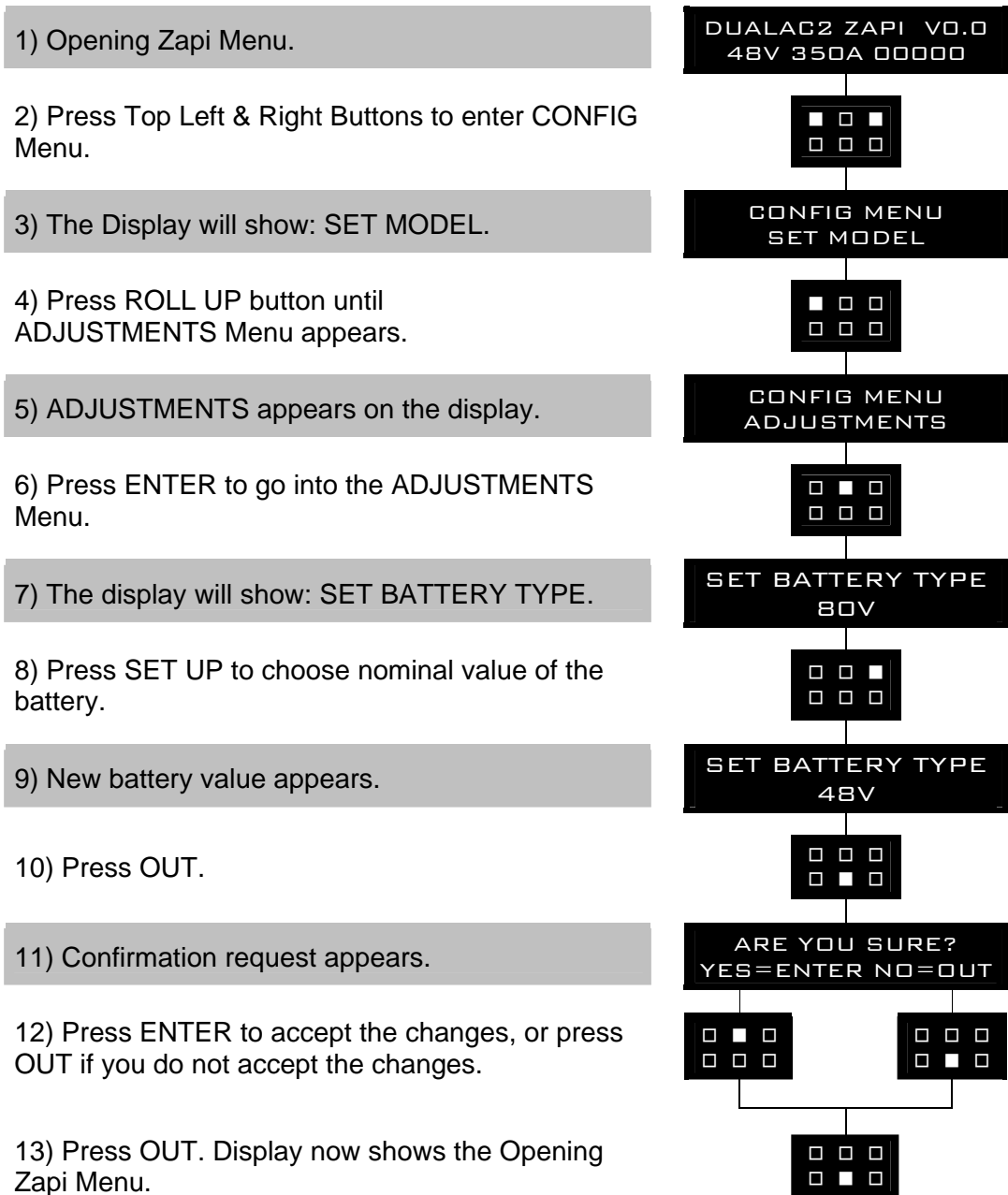

Flow chart showing how to carry out ADJUSTMENT BATTERY operation by console.

1) Opening Zapi Menu.

DUALAC2 ZAPI V0.0
48V 350A 00000

2) Press Top Left & Right Buttons to enter CONFIG Menu.

■ □ □
□ □ □

3) The Display will show: SET MODEL.

CONFIG MENU
SET MODEL

4) Press ROLL UP button until ADJUSTMENTS Menu appears.

■ □ □
□ □ □

5) ADJUSTMENTS appears on the display.

CONFIG MENU
ADJUSTMENTS

6) Press ENTER to go into the ADJUSTMENTS Menu.

□ ■ □
□ □ □

7) The display will show the first OPTION.

SET POT BRK MIN
0.0V

8) Press ROLL UP or ROLL DOWN button until desired OPTION appears.

■ □ □
■ □ □

9) ADJUST BATTERY appears.

ADJUSTMENT BATTERY
82.1V

10) Press SET UP or SET DOWN button in order to increase or decrease respectively. Set the value read by an external voltmeter.

□ □ ■
□ □ ■

11) Battery value appears on the display.

ADJUSTMENT BATTERY
84.5V

12) Press OUT to exit the Menu.

□ □ □
□ ■ □

13) Confirmation request appears.

ARE YOU SURE?
YES=ENTER NO=OUT

14) Press ENTER to accept the changes, or press OUT if you do not accept the changes.

□ ■ □ □ □ □
□ □ □ □ ■ □

15) ADJUSTMENTS Menu appears.

CONFIG MENU
ADJUSTMENTS

16) Press OUT. Display now show the Opening Zapi Menu.

□ □ □
□ ■ □

8.5 Parameter regulation

8.5.1 "Dualac2" - Master

The following parameters can be modified:

- 1) **ACCELER. DELAY**
It determines the acceleration ramp.
- 2) **RELEASE BRAKING**
It controls the deceleration ramp when the travel request is released.
- 3) **INVERSION BRAKING**
It controls the deceleration ramp when the direction switch is inverted during travel.
- 4) **PEDAL BRAKING**
It determines the deceleration ramp when the travel request is released and the brake pedal switch is closed.
- 5) **SPEED LIMIT BRAKING**
Deceleration ramp when the pedal position is changed but not completely released.
- 6) **BRAKE CUTBACK**
It determines the deceleration ramp when the speed reduction input becomes active and the motor slow down.
- 7) **MAX SPEED FORWARD**
It determines the maximum speed in forward direction.
- 8) **MAX SPEED BACKWARD**
It determines the maximum speed in backward direction.
- 9) **CUTBACK SPEED 1**
Typically from 10% to 100%. It determines the percentage of the max speed applied when the cutback switch is active. When set to 100% the speed reduction is ineffective.
- 10) **CURVE CUTBACK**
Speed reduction when the truck is doing a curve. The parameter sets the speed setpoint when the truck driving wheels are running in opposite direction (3 wheels truck, steering angle greater than roughly 67°); or when the maximum steering angle is reached (4 wheels truck, the internal wheel is stopped). In intermediate steering angles, the speed setpoint will be within a range between the straight wheel speed and the CURVE CUTBACK SPEED.
- 11) **FREQUENCY CREEP**
Minimum speed when the forward or reverse switch is closed, but the accelerator is on a minimum position.
- 12) **MAXIMUM CURRENT**
This changes the maximum current of the inverter.
- 13) **BACKING SPEED**
Drive Motor Speed during the Backing function (when the backing switch is closed).
- 14) **BACKING TIME**
Operation time of the Backing Function, during which the backing switch is closed.
- 15) **ACC. SMOOTH**
It gives a different form to the acceleration curve in the frequency range 0 Hz to "Stop smooth" value (see the figure below).
- 16) **INV. SMOOTH**
It gives a different form to the acceleration curve after a direction inversion in the frequency range 0 Hz to "Stop smooth" value (see the figure below).

17) STOP SMOOTH

It sets the level of frequency where the smooth effect on the acceleration ramp ends.

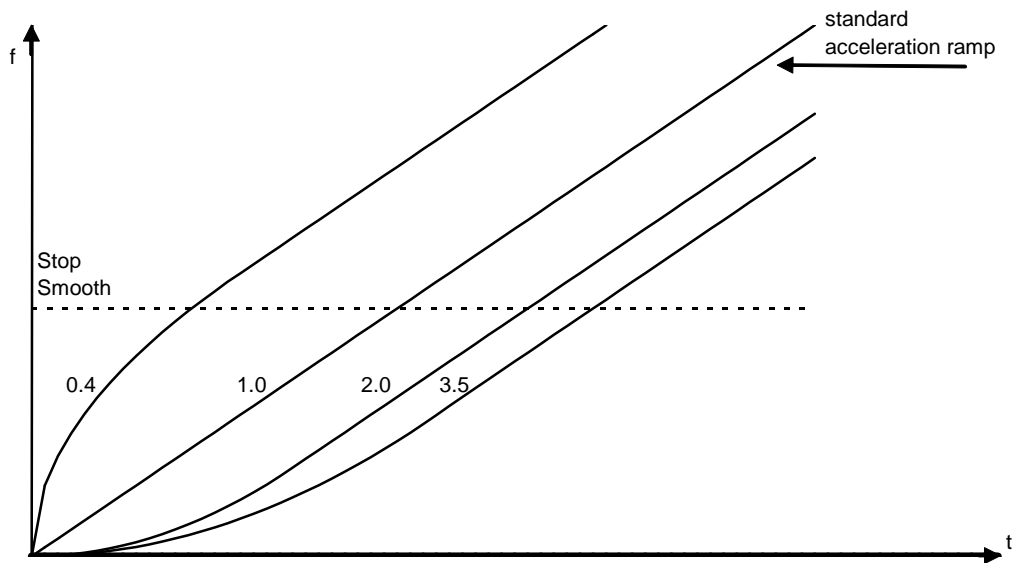

0.4, 1.0, 2.0, 3.5 are some possible values of the "Acc. Smooth" and "Inv. Smooth" parameters (see the table below).

18) AUXILIARY TIME

It determines the time that the truck is hold on the ramp if the "stop on ramp" option is ON.

The following table shows the different values at which the parameters can be set.

PARAMETER	UNIT	PROGRAMMED LEVEL									
		0	1	2	3	4	5	6	7	8	9
ACCELERATION DELAY (*)	Sec.	1.0	1.5	2.0	2.5	3.0	3.5	4.0	4.5	5.0	5.5
RELEASE BRAKING (**)	Sec.	5.5	5.0	4.5	4.0	3.5	3.0	2.5	2.0	1.5	1.0
INVERSION BRAKING (**)	Sec.	5.5	5.0	4.5	4.0	3.5	3.0	2.5	2.0	1.5	1.0
PEDAL BRAKING (**)	Sec.	4.0	3.5	3.0	2.5	2.0	1.5	1.2	1.0	0.7	0.5
SPEED LIMIT BRAKING (**)	Sec.	8.9	8.3	7.7	7.1	6.6	6.0	5.5	4.9	4.4	3.8
BRAKE CUTBACK (**)	Sec.	5.5	5.0	4.5	4.0	3.5	3.0	2.5	2.0	1.5	1.0
MAX SPEED FW	Hz	65	80	95	110	125	140	155	170	185	200
MAX SPEED BW	Hz	65	80	95	110	125	140	155	170	185	200
CUTBACK SPEED 1	%	10	20	30	40	50	60	70	80	90	100
CURVE CUTBACK	%	10	15	20	25	38	50	63	75	87	100
FREQUENCY CREEP	Hz	0.3	0.6	0.9	1.2	1.5	1.8	2.1	2.4	2.7	3.0
MAXIMUM CURRENT	%IMAX	47	53	59	65	70	76	82	88	94	100
BACKING SPEED	Hz	0	2	4	6	8	10	12	14	16	18
BACKING TIME	Sec.	0.3	1.1	1.9	2.8	3.7	4.5	5.4	6.3	7.1	8.0
ACC. SMOOTH		1.0	1.2	1.5	1.7	2.0	2.2	2.5	2.7	3.0	3.5
INV. SMOOTH		0.4	0.6	0.8	1.0	1.2	1.5	1.7	2.0	2.5	3.0
STOP SMOOTH	Hz	5	7	10	12	15	17	20	22	25	27
AUXILIARY TIME	Sec.	0	0.2	0.4	0.8	1	1.5	2	3	4	5

(*) The acceleration time shown is the time from 0 Hz to 100 Hz. This is the ideal ramp calculated by the software; the real ramp could change as a function of motor control parameter setting and, obviously, as a function of the load.

(**) The braking feature is based upon deceleration ramps. The value shown in the table is the time to decrease the speed from 100 Hz to 0 Hz. This is the ideal ramps calculated by the software; the real ramp could change as a function of motor control parameter setting and, obviously, as a function of the load.

8.5.2 "Dualac2" - Slave

The menu is not available.

8.5.3 "Dualac2&hp" – Master

See chapter 8.5.1.

8.5.4 "Dualac2&hp" - Slave

Here following the list of parameters which can be set in this menu:

1) SPEED LIMIT

It determines the maximum lifting speed (per cent of voltage applied to the motor) with a potentiometer control, when the potentiometer is at the maximum of the programmed range.

2) PUMP IMAX

The maximum current of pump chopper.

- 3) **PU. ACCELER. DELAY**
Acceleration ramp of pump motor.
- 4) **PU. DECELER. DELAY**
Deceleration ramp of pump motor.
- 5) **CREEP SPEED**
It determines the minimum lifting speed (per cent of voltage applied to the motor) with a potentiometer control, when the potentiometer is at the minimum of the programmed range.
- 6) **COMPENSATION**
This parameter sets the voltage compensation (DV) applied to the motor when the proportional lifting function is active. The value of this DV applied to the motor is a function of the motor current. Aim of this function is to reduce, as far as possible, the speed change when the motor is loaded. Increasing the parameter, the DV will be increased.
- 7) **1ST SPEED FINE**
This parameter sets the pump motor speed (voltage applied to the motor) when the 1st speed request is active.
- 8) **1ST SPEED COMP.**
This parameter sets the voltage compensation (DV) applied to the motor when the 1st speed request is active. The value of DV applied to the motor is a function of the motor current. Aim of this function is to reduce, as far as possible, the speed change when the motor is loaded. Increasing the parameter, the DV is increased.
- 9) **2ND SPEED FINE**
This parameter sets the voltage compensation (DV) applied to the motor when the 2nd speed request is active. The value of DV applied to the motor is a function of the motor current. Aim of this function is to reduce, as far as possible, the speed change when the motor is loaded. Increasing the parameter, the DV is increased.
- 10) **2ND SPEED COMP.**
This parameter sets the voltage compensation (DV) applied to the motor when the 2nd speed request is active. The value of DV applied to the motor is a function of the motor current. Aim of this function is to reduce, as far as possible, the speed change when the motor is loaded. Increasing the parameter, the DV is increased.
- 11) **3RD SPEED FINE**
This parameter sets the voltage compensation (DV) applied to the motor when the 3rd speed request is active. The value of DV applied to the motor is a function of the motor current. Aim of this function is to reduce, as far as possible, the speed change when the motor is loaded. Increasing the parameter, the DV is increased.
- 12) **3RD SPEED COMP.**
This parameter sets the voltage compensation (DV) applied to the motor when the 3rd speed request is active. The value of DV applied to the motor is a function of the motor current. Aim of this function is to reduce, as far as possible, the speed change when the motor is loaded. Increasing the parameter, the DV is increased.
- 13) **4TH SPEED FINE**
This parameter sets the voltage compensation (DV) applied to the motor when the 4th speed request is active. The value of DV applied to the motor is a function of the motor current. Aim of this function is to reduce, as far as possible, the speed change when the motor is loaded. Increasing the parameter, the DV is increased.
- 14) **4TH SPEED COMP.**
This parameter sets the voltage compensation (DV) applied to the motor

when the 4th speed request is active. The value of DV applied to the motor is a function of the motor current. Aim of this function is to reduce, as for as possible, the speed change when the motor is loaded. Increasing the parameter, the DV is increased.

15) 5TH SPEED FINE

This parameter sets the voltage compensation (DV) applied to the motor when the 5th speed request is active. The value of DV applied to the motor is a function of the motor current. Aim of this function is to reduce, as for as possible, the speed change when the motor is loaded. Increasing the parameter, the DV is increased.

16) 5TH SPEED COMP.

This parameter sets the voltage compensation (DV) applied to the motor when the 5th speed request is active. The value of DV applied to the motor is a function of the motor current. Aim of this function is to reduce, as for as possible, the speed change when the motor is loaded. Increasing the parameter, the DV is increased.

17) HYDRO SPEED FINE

This parameter sets the pump motor speed (voltage applied to the motor) when the hydraulic steering function request is active.

18) HYDRO COMPENS.

This parameter sets the voltage compensation (DV) applied to the motor when the hydro speed request is active. The value of DV applied to the motor is a function of the motor current. Aim of this function is to reduce, as for as possible, the speed change when the motor is loaded. Increasing the parameter, the DV is increased.

19) HYDRO TIME

Hydraulic steering function delay.

The following table shows all the values of parameters.

PARAMETER	UNIT	PROGRAMMED LEVEL									
		0	1	2	3	4	5	6	7	8	9
SPEED LIMIT	%	0 - 100									
PUMP IMAX	%IMAX	50	55	61	66	72	77	83	88	94	100
PUMP ACCELER DELAY (*)	Sec.	0.2	0.4	0.6	0.8	1	1.5	2	2.5	3	3.5
PUMP DECELER DELAY (**)	Sec.	0.2	0.4	0.6	0.8	1	1.5	2	2.5	3	3.5
CREEP SPEED	%	0 - 100									
COMPENSATION	%	0 - 100									
1ST SPEED FINE	%	0 - 100									
1ST SPEED COMP.	%	0 - 100									
2ND SPEED FINE	%	0 - 100									
2ND SPEED COMP.	%	0 - 100									
3RD SPEED FINE	%	0 - 100									
3RD SPEED COMP.	%	0 - 100									
4TH SPEED FINE	%	0 - 100									
4TH SPEED COMP.	%	0 - 100									
5TH SPEED FINE	%	0 - 100									
5TH SPEED COMP.	%	0 - 100									
HYDRO SPEED FINE	%	0 - 100									
HYDRO COMPENS.	%	0 - 100									
HYDRO TIME	Sec.	0 - 25.5									

(*) The acceleration time shown is the theoretical time to change from 0V to full voltage applied to the motor. This is an ideal ramp, the real ramp can change as a function of the load.

(**) The deceleration feature is based upon deceleration ramps. The value shown in the table is the time to decrease the voltage applied to the motor from 100% down to 0%.

After changing a parameter, press ENTER to confirm data when requested by the message on the console. Parameters modified and optimized on one unit can be stored by the Zapi Pc-console (SAVE) and then downloaded (RESTORE) to another controller, thus allowing fast and standardized settings (see Pc-console manual for details).

Flow Chart showing how to make Parameter changes using Digital Console fitted with Eprom CK ULTRA.

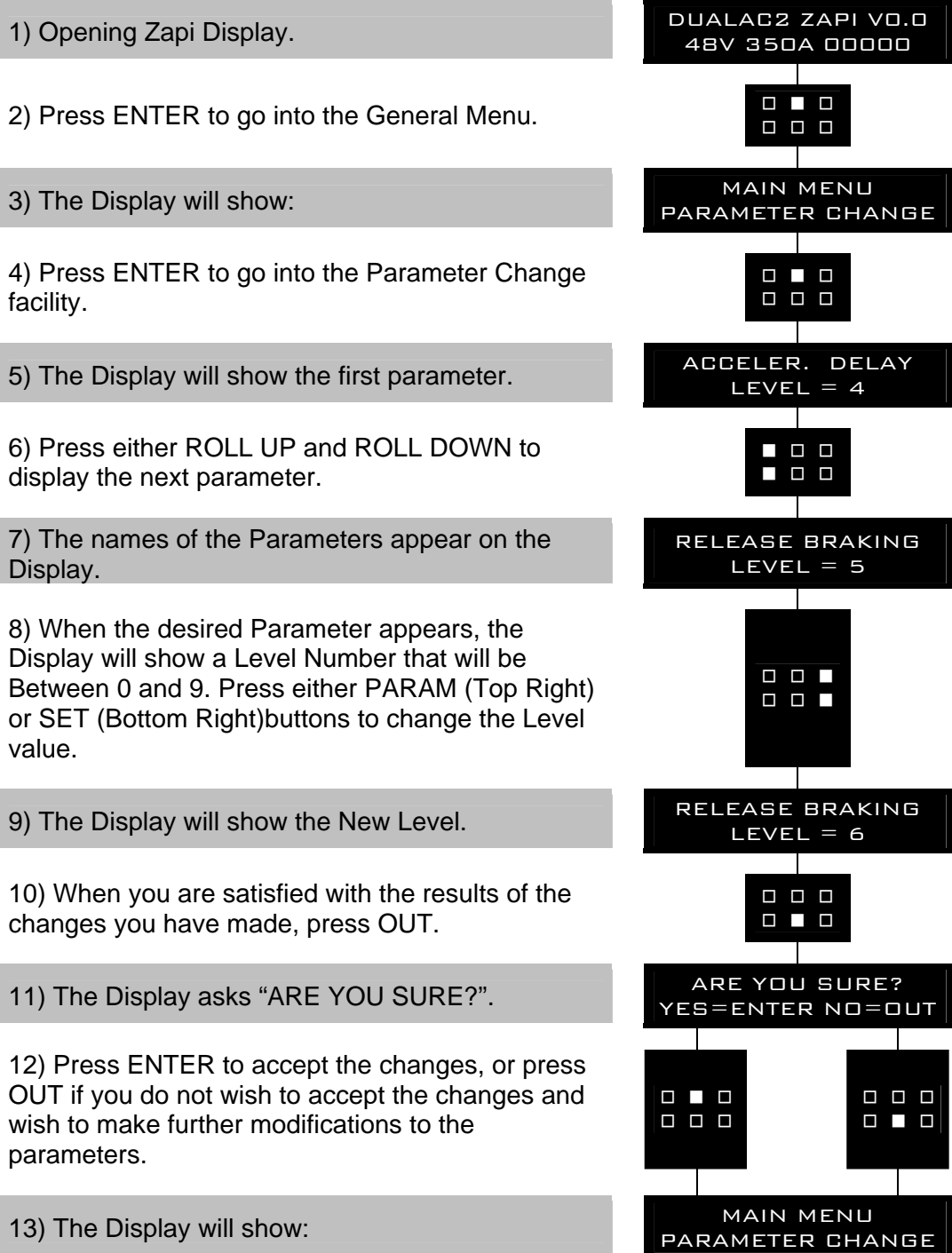

8.6 Programming console functions

8.6.1 "Dualac2" and "Dualac2 Power"

- Functional configuration (see 8.4)
- Parameter programming (see 8.5)
- Tester: user can verify the state of the following parameters:

MASTER	SLAVE
motor voltage (%)	motor voltage (%)
frequency (Hz)	frequency (Hz)
encoder (Hz)	encoder (Hz)
slip value (Hz)	slip value (Hz)
current rms (A)	current rms (A)
temperature (°C)	temperature (°C)
temperature #1(°C)	voltage booster (%)
temperature #2(°C)	battery voltage (V)
accelerator (V)	seat switch (ON/OFF)
steer angle (°)	forward switch (ON/OFF)
int. wheel cutback (%)	backward switch (ON/OFF)
forward switch (ON/OFF)	enable switch (ON/OFF)
backward switch (ON/OFF)	
enable switch (ON/OFF)	
seat switch (ON/OFF)	
backing switch (ON/OFF)	
cutback switch (ON/OFF)	
brake switch (ON/OFF)	
exclusive hydro (ON/OFF)	
brakepedal pot. (%)	
handbrake (ON/OFF)	
voltage booster (%)	
battery voltage (V)	
battery charge (%)	
hours-meter	
- Save function (for storing data) --> only with Pc-console.
- Restore function (for downloading parameters to another controller) --> only with Pc-console.
- Display of the last 5 alarms including hour-meter value and temperature at the moment of the alarm.
- Accelerator range programming.
Records the minimum and maximum useful accelerator stroke values for both direction of running.
- See the console manual for a detailed description of function and parameters.

8.6.2 "Dualac2&hp" and "Dualac2&hp Power"

- Functional configuration (see 8.4)
- Parameter programming (see 8.5)
- Tester: user can verify the state of the following parameters:

MASTER	SLAVE
motor voltage (%)	motor voltage (%)
frequency (Hz)	frequency (Hz)
encoder (Hz)	encoder (Hz)
slip value (Hz)	slip value (Hz)

current rms (A)	current rms (A)
temperature (°C)	temperature (°C)
temperature #1(°C)	voltage booster (%)
temperature #2(°C)	battery voltage (V)
accelerator (V)	seat switch (ON/OFF)
steer angle (°)	forward switch (ON/OFF)
int. wheel cutback (%)	backward switch (ON/OFF)
forward switch (ON/OFF)	enable switch (ON/OFF)
backward switch (ON/OFF)	lifting control (V)
enable switch (ON/OFF)	lifting switch (ON/OFF)
seat switch (ON/OFF)	1st speed switch (ON/OFF)
backing switch (ON/OFF)	2nd speed switch (ON/OFF)
cutback switch (ON/OFF)	3rd speed switch (ON/OFF)
brake switch (ON/OFF)	4th speed switch (ON/OFF)
exclusive hydro (ON/OFF)	5th speed switch (ON/OFF)
brakepedal pot. (%)	pump current (A)
handbrake (ON/OFF)	pump voltage (V)
voltage booster (%)	pump temperature (°C)
battery voltage (V)	
battery charge (%)	
hours-meter	

- Save function (for storing data) --> only with Pc-console.
- Restore function (for downloading parameters to another controller) --> only with Pc-console.
- Display of the last 5 alarms including hour-meter value and temperature at the moment of the alarm.
- Accelerator range programming.
Records the minimum and maximum useful accelerator stroke values for both direction of running.
- See the console manual for a detailed description of function and parameters.

8.7 Sequence for Ac Traction Inverter setting

When the "Key Switch" is closed, if no alarms or errors are present, the Console Display will be showing the Standard Zapi Opening Display.

If the controller is not configured to your requirements, follow the sequence detailed here following. Remember to re-cycle the Key Switch if you make any changes to the inverter's configuration.

- 1) Select the Options required. See Chapter 8.4.
- 2) Select and set the Battery Voltage. See Chapter 8.4.
- 3) Confirm correct installation of all wires. Use the Console's TESTER function to assist.
- 4) Perform the accelerator signal acquisition procedure using the Console "PROGRAM VACC". Procedure is detailed on Chapter 9.3.
- 5) Perform the steering potentiometer signal acquisition, using the parameters in "Adjustment" menu (see Chapter 8.4).
Remember: turning the wheel to right direction, voltage has to increase.
- 6) Set the maximum steering angles, right and left direction; use the parameters in "Adjustments" menu (see Chapter 8.4).
- 7) Set the "MAXIMUM CURRENT" Current, using the table on Chapter 8.5.1.
- 8) Set the Acceleration Delay requirements for the machine. Test the parameter setting in both directions.

- 9) Set the FREQUENCY CREEP level starting from level 0.3 Hz. The machine should just move when the accelerator microswitch is closed. Increase the Level accordingly.
- 10) Set the Speed Reductions as required. Make adjustments to "CUTBACK SPEED 1" Check the performance with the accelerator pedal totally depressed. If the machine is a forklift, check the performance with and without load.
- 11) RELEASE BRAKING. Operate the machine at full speed. Release the accelerator pedal. Adjust the level to your requirements. If the machine is a forklift, check the performance with and without load.
- 12) INVERSION BRAKING. Operate the machine at 25% full speed. Whilst travelling INVERT the Direction Switch. Set a soft Level of Inversion Braking. When satisfactory, operate the machine at Full Speed and repeat. If the machine is a Forklift, repeat the tests and make adjustments with and without load. The unladen full speed condition should be the most representative condition.
- 13) PEDAL BRAKING (If used). Operate the machine at full Speed. Release the accelerator pedal and press the Pedal Brake. Set braking level to your requirements.
- 14) Set "MAX SPEED FORW".
- 15) Set "MAX SPEED BACK" (Reverse).
- 16) Set "BACKING SPEED" and "BACKING TIME" if these options are used.
- 17) Make the choice for the truck behaviour on a slope (see chapter 8.4). If the "Stop on ramp" option is ON, set the desired value of "auxiliary time" parameter.
- 18) Set "SET TEMPERATURE", setting the motor thermal sensor type used.
- 19) Set "MAIN CONT VOLTAGE", setting the main contactor coil voltage.
- 20) Set "AUX OUTPUT VOLTAGE" (if used), setting the auxiliary output voltage.

8.8 Sequence for Dc Pump Chopper setting (DUALAC&HP only)

When the "Key Switch" is closed, if no alarms or errors are present, the Console Display will be showing the Standard Zapi Opening Display.

If the controller is not configured to your requirements, follow the sequence detailed here following. Remember to re-cycle the Key Switch if you make any changes to the controller's configuration.

- 1) Select the Options required.
- 2) Select and set the Battery Voltage.
- 3) Confirm correct installation of all wires. Use the Console's TESTER function to assist.
- 4) Perform the lift signal acquisition procedure using the Console "PROGRAM VACC".
- 5) Set the "MAXIMUM CURRENT" Current.
- 6) Set the Acceleration and Deceleration Delay requirements for the pump.
- 7) Set the "MIN SPEED LIFT" level starting from 0 Hz. The pump should just turn when the request microswitch is closed. Increase the level accordingly.
- 8) Set the Speed Reductions as required. Make adjustments to "CUTBACK SPEED". Check the performance with the full request. Check the performance with and without load.
- 9) Set "MAX SPEED LIFT" (max speed of pump motor).
- 10) Set "HYD SPEED FINE" to adjust the hydraulic steering speed (pump motor speed when HYDRO function is requested).
- 11) Set "AUXILIARY TIME" (time delay before pump stops when an hydraulic

- steering function request is switched off).
- 12) Set "SET TEMPERATURE", setting the motor thermal sensor type used.

8.9 Tester: description of the function

The most important input or output signals can be measured in real time using the TESTER function of the console. The Console acts as a multimeter able to read voltage, current and temperature. In the following chapter a list of relative measurements for different configurations.

8.9.1 "Dualac2" and "Dualac2 Power" - Master

- 1) **MOTOR VOLTAGE**
This is the voltage supplied to the motor by the inverter; it is expressed as a percentage of the full voltage (which depends of the battery voltage).
- 2) **FREQUENCY**
This is the frequency of the voltage and current supplied to the motor.
- 3) **ENCODER**
This is the speed of the motor, expressed in the same unit of the frequency; this information comes from the speed sensor.
- 4) **SLIP VALUE**
This is the difference of speed between the rotating field and the shaft of the motor, expressed in the same unit of the frequency.
- 5) **CURRENT RMS**
Root Mean Square value of the motor current.
- 6) **TEMPERATURE**
The temperature measured on the aluminium heat sink holding the MOSFET devices.
- 7) **TEMPERATURE #1**
This is the temperature of the right motor; if the option is programmed "None" (see chapter 8.4.a) it shows 0°.
- 8) **TEMPERATURE #2**
This is the temperature of the left motor; if the option is programmed "None" (see chapter 8.4.a) it shows 0°.
- 9) **ACCELERATOR**
The voltage of the accelerator potentiometer's wiper (CPOT). The voltage level is shown on the Left Hand Side of the Console Display and the value in percentage is shown on the Right Hand Side.
- 10) **STEER ANGLE**
This is the indication of the angular position of the steered wheel.
- 11) **INTERNAL WHEEL CUTBACK**
This is the indication of the speed reduction applied to the internal wheel; in other words, it shows the ratio of the two speeds.
- 12) **FORWARD SWITCH**
The level of the Forward direction digital input FW.
 - ON / +VB = input active, switch closed.
 - OFF / GND = input non active, switch open.
- 13) **BACKWARD SWITCH**
The level of the Reverse direction digital input BW.
 - ON / +VB = input active, switch closed.
 - OFF / GND = input non active, switch open.
- 14) **ENABLE SWITCH**
The level of the Enable digital input:
 - ON / +VB = input active, switch closed.
 - OFF / GND = input non active, switch open.

15) SEAT SWITCH

The level of the Seat Microswitch digital input.

- ON / +VB = input active, switch closed.
- OFF / GND = input non active, switch open.

16) BACKING SWITCH

The level of the Backing Microswitch.

- ON / +VB = input active, switch closed.
- OFF / GND = input non active, switch open.

17) CUTBACK SWITCH

The level of the Speed Reduction Microswitch.

- ON / GND = input active, switch opened.
- OFF / +VB = input non active, switch closed.

18) BRAKE SWITCH

The level of the Pedal Brake Microswitch.

- ON / +VB = input active, switch closed.
- OFF / GND = input non active, switch open.

19) EXCLUSIVE HYDRO

Status of the exclusive hydro switch.

- ON / +VB = input active, switch closed.
- OFF / GND = input non active, switch open.

20) BRAKEPEDAL POT.

Voltage of the brake potentiometer's wiper (CPOTB). The parameter is active only if the PEDAL BRAKING parameter is set ANALOG (see chapter 8.4.).

21) HANDBRAKE

The level of the Handbrake Microswitch.

- ON / GND = input active, switch opened.
- OFF / +VB = input non active, switch closed.

22) VOLTAGE BOOSTER

This is the booster of the voltage supplied to the motor in load condition; it is expressed in a percentage of the full voltage.

23) BATTERY VOLTAGE

Level of battery voltage measured at the input of the key switch.

24) BATTERY CHARGE

The percentage Charge level of the battery.

25) HOURS-METER

This is the machine hour meter value.

8.9.2 "Dualac2" and "Dualac2 Power" - Slave

1) MOTOR VOLTAGE

This is the voltage supplied to the motor by the inverter; it is expressed as a percentage of the full voltage (which depends of the battery voltage).

2) FREQUENCY

This is the frequency of the voltage and current supplied to the motor.

3) ENCODER

This is the speed of the motor, expressed in the same unit of the frequency; this information comes from the speed sensor.

4) SLIP VALUE

This is the difference of speed between the rotating field and the shaft of the motor, expressed in the same unit of the frequency.

5) CURRENT RMS

Root Mean Square value of the motor current.

6) TEMPERATURE

The temperature measured on the aluminium heat sink holding the MOSFET devices.

7) VOLTAGE BOOSTER

This is the booster of the voltage supplied to the motor in load condition; it is expressed in a percentage of the full voltage.

8) BATTERY VOLTAGE

Level of battery voltage measured at the input of the key switch.

9) SEAT SWITCH

The level of the Seat Microswitch digital input.

- ON / +VB = input active, switch closed.
- OFF / GND = input non active, switch opened.

10) FORWARD SWITCH

The level of the Forward direction digital input FW.

- ON / +VB = input active, switch closed.
- OFF / GND = input non active, switch opened.

11) BACKWARD SWITCH

The level of the Reverse direction digital input BW.

- ON / +VB = input active, switch closed.
- OFF / GND = input non active, switch opened.

12) ENABLE SWITCH

The level of the Enable digital input:

- ON / +VB = input active, switch closed.
- OFF / GND = input non active, switch open.

8.9.3 "Dualac2&hp" and "Dualac2&hp Power" – Master

See chapter 8.9.1.

8.9.4 "Dualac2&hp" and "Dualac2&hp Power" - Slave

1) MOTOR VOLTAGE

This is the voltage supplied to the motor by the inverter; it is expressed as a percentage of the full voltage (which depends of the battery voltage).

2) FREQUENCY

This is the frequency of the voltage and current supplied to the motor.

3) ENCODER

This is the speed of the motor, expressed in the same unit of the frequency; this information comes from the speed sensor.

4) SLIP VALUE

This is the difference of speed between the rotating field and the shaft of the motor, expressed in the same unit of the frequency.

5) CURRENT RMS

Root Mean Square value of the motor current.

6) TEMPERATURE

The temperature measured on the aluminium heat sink holding the MOSFET devices.

7) VOLTAGE BOOSTER

This is the booster of the voltage supplied to the motor in load condition; it is expressed in a percentage of the full voltage.

8) BATTERY VOLTAGE

Level of battery voltage measured at the input of the key switch.

9) SEAT SWITCH

The level of the Seat Microswitch digital input.

- ON / +VB = input active, switch closed.
- OFF / GND = input non active, switch open.

10) FORWARD SWITCH

The level of the Forward direction digital input FW.

- ON / +VB = input active, switch closed.
- OFF / GND = input non active, switch open.

11) BACKWARD SWITCH

The level of the Reverse direction digital input BW.

- ON / +VB = input active, switch closed.
- OFF / GND = input non active, switch open.

12) ENABLE SWITCH

The level of the Enable digital input:

- ON / +VB = input active, switch closed.
- OFF / GND = input non active, switch open.

13) LIFTING CONTROL

Voltage of the lifting potentiometer (CPOT LIFT).

14) LIFTING SWITCH

Status of the lifting switch.

- ON / +VB = input active, switch closed.
- OFF / GND = input non active, switch open.

15) 1ST SPEED SWITCH

Status of the first speed switch of the hydraulic system.

- ON / +VB = input active, switch closed.
- OFF / GND = input non active, switch open.

16) 2ND SPEED SWITCH

Status of the second speed switch of the hydraulic system.

- ON / +VB = input active, switch closed.
- OFF / GND = input non active, switch open.

17) 3RD SPEED SWITCH

Status of the third speed switch of the hydraulic system..

- ON / +VB = input active, switch closed.
- OFF / GND = input non active, switch open.

18) 4TH SPEED SWITCH

Status of the fourth speed switch of the hydraulic system..

- ON / +VB = input active, switch closed.
- OFF / GND = input non active, switch open.

19) 5TH SPEED SWITCH

Status of the fifth speed switch of the hydraulic system..

- ON / +VB = input active, switch closed.
- OFF / GND = input non active, switch open.

20) PUMP CURRENT

Current of the pump motor.

21) PUMP VOLTAGE

Voltage between pump chopper output and -BATT.

22) PUMP TEMPERATURE

Temperature of pump chopper power section.

Flow Chart showing how to use the TESTER function of the Digital Console.

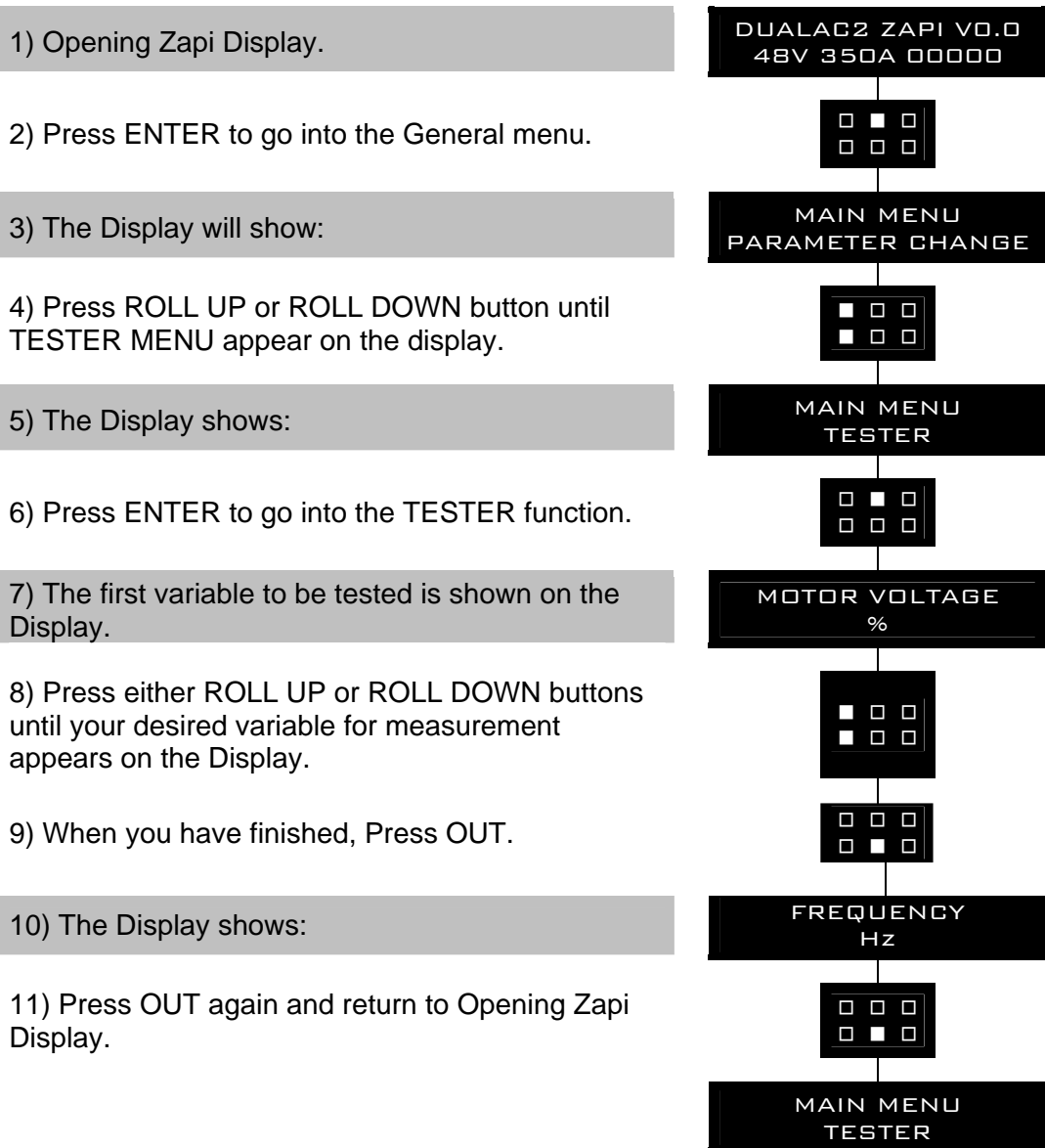

Remember it is not possible to make any changes using TESTER. All you can do is measure as if you were using a pre-connected multimeter.

9 OTHER FUNCTIONS

9.1 Save and Restore function

SAVE function allows to transfer controller parameters to the Pc console memory. With this function, a copy of the controller set of parameters can be retained in a Pc and downloaded to another controller (see RESTORE). RESTORE function allows to download controller parameters from the Pc console memory to the controller Eeprom. Thus a copy of the parameters stored in a Pc can be downloaded in a controller avoiding the parameter setting operation.

For more details, please refer to Pc console manual.

9.2 Description of Alarms menu

The microprocessor in the controller records the last five Alarms that have occurred. Items remembered relative to each Alarm are: the code of the alarm, the number of times the particular Alarm occurred, the Hour Meter count, and the inverter temperature.

This function permits a deeper diagnosis of problems as the recent history can now be accessed.

Flow Chart showing how to use the ALARMS function via the Digital Console.

1) Opening Zapi Display.

```
DUALAC2 ZAPI V0.0
48V 350A 00000
```

2) Press ENTER to go into the General menu.

```
□ ■ □
□ □ □
```

3) The Display will show:

```
MAIN MENU
PARAMETER CHANGE
```

4) Press ROLL UP or ROLL DOWN button until PARAMETER CHANGE appears on the display.

```
■ □ □
■ □ □
```

5) The Display will show:

```
MAIN MENU
ALARMS
```

6) Press ENTER to go into the ALARMS function.

```
□ ■ □
□ □ □
```

7) The Display will show the most recent Alarm.

```
CODE
00005 #02 20°C
```

8) Each press of the ROLL UP button brings up following Alarms. Pressing ROLL DOWN returns to the most recent.

```
■ □ □
■ □ □
```

9) If an Alarm has not occurred, the Display will show: ALARM NULL.

```
CODE
00007 #03 18°C
```

10) When you have finished looking at the Alarms, press OUT to exit the ALARMS menu.

11) The Display will ask "CLEAR LOGBOOK?".

12) Press ENTER for yes, or OUT for NO.

13) Press OUT to return to the Opening Zapi Display.

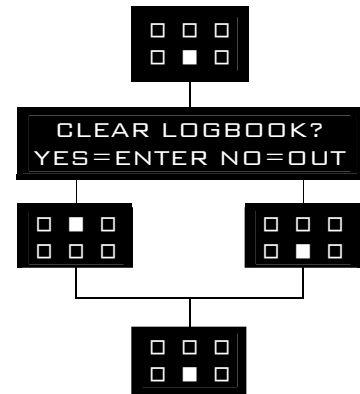

9.3 Description of Console Program Vacc function

This function looks for and remembers the minimum and maximum potentiometer wiper voltage over the full mechanical range of the pedal. It enables compensation for non symmetry of the mechanical system between directions. The operation is performed by operating the pedal after entering the PROGRAM VACC function.

Flow Chart showing how to use the PROGRAM VACC function of the Digital Console:

1) Opening Zapi Display.

2) Press ENTER to go into the General Menu.

3) The Display will show:

4) Press ROLL UP or ROLL DOWN button until PROGRAM VACC appears on the display.

5) The Display will show:

6) Press ENTER to go into the PROGRAM VACC routine.

7) The Display will show the minimum and maximum values of potentiometer wiper output. Both directions can be shown.

8) Press ENTER to clear these values. Display will show 0.0.

9) Select Forward Direction, close any interlock switches that may be in the system.

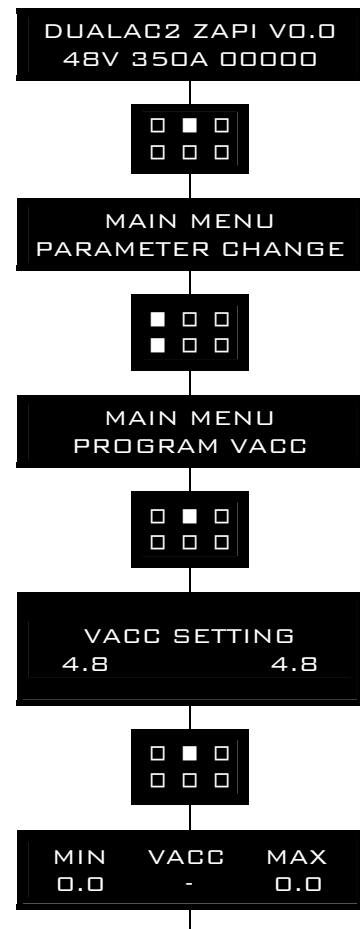

10) Slowly depress the accelerator pedal (or tiller butterfly) to its maximum value. The new minimum and maximum voltages will be displayed on the Console plus an arrow indicating the direction.

11) Select the Reverse Direction and repeat Item 10.

12) When finished, press OUT.

13) The Display will ask: "ARE YOU SURE?".

14) Press ENTER for yes, or OUT for NO.

15) When finished, the Console shows:

16) Press OUT again to return to the Opening Zapi Menu.

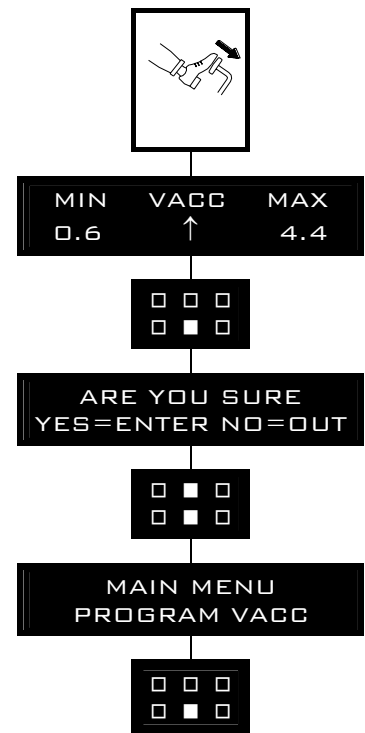

10 "DUALAC2" AND "DUALAC2&HP" INVERTER DIAGNOSTIC

10.1 Traction related fault codes

Code	ALARM STRING	Master	Slave	CONTROLLER STATUS			DESCRIPTION	Condition that has to occur to come out from alarm status
				Init	Stby	Motor running		
8	WATCHDOG	X	X	X	X	X	<u>Alarm:</u> the Watchdog circuit has been triggered	-If the alarm is present in Init status, remove the alarm condition -If the alarm has occurred in stby or running mode, it is necessary to remove alarm condition and to activate a traction request
17	LOGIC FAILURE #3	X	X		X		<u>Alarm:</u> failure in over-load protection hw circuit	To remove alarm condition + activation of traction request
18	LOGIC FAILURE #2	X	X	X			<u>Alarm:</u> failure in U, V, W voltage feedback circuit	To remove alarm condition + activation of traction request
19	LOGIC FAILURE #1	X	X	X	X	X	<u>Alarm:</u> an overvoltage or undervolt. condition has been detected	To recycle the key switch
30	VMN LOW	X	X	X	X	X	<u>Alarm:</u> wrong voltage on motor power outputs; failure in the power section or in the mosfet driver circuit or in the motor	-If the alarm is present in Init status, remove the alarm condition -If the alarm has occurred in stby or running mode, it is necessary to remove alarm condition and to activate a traction request

<u>Code</u>	<u>ALARM STRING</u>	<u>Master</u>	<u>Slave</u>	<u>CONTROLLER STATUS</u>			<u>DESCRIPTION</u>	<u>Condition that has to occur to come out from alarm status</u>
				<u>Init</u>	<u>Stby</u>	<u>Motor running</u>		
31	VMN HIGH	X	X	X	X		<u>Alarm:</u> wrong voltage on motor power outputs; failure in the power section or in the mosfet driver circuit or in the motor	-If the alarm is present in Init status, remove the alarm condition -If the alarm has occurred in stby or running mode, it is necessary to remove alarm condition and to activate a traction request
53	STBY I HIGH	X	X	X	X		<u>Alarm:</u> wrong voltage in the current sensor feedback circuit	-If the alarm is present in Init status, remove the alarm condition -If the alarm has occurred in stby or running mode, it is necessary to remove alarm condition and to activate a traction request
60	CAP CHARGE	X	X	X			<u>Alarm:</u> power capacitor voltage does not increase when the key is turned ON; failure in the power section, or in the Logic PCB, or in the driver PCB, or in the motor	To remove alarm condition
74	DRIVER SHORTED	X		X	X	X	<u>Alarm:</u> line contactor coil driver is shorted	-If the alarm is present in Init status, remove the alarm cause -If the alarm has occurred in stby or running mode, it is necessary to remove alarm cause and to activate traction request
75	CONTACTOR DRIVER	X			X	X	<u>Alarm:</u> line contactor coil driver is open (not able to drive the coil to the correct voltage)	To remove alarm cause and to activate traction request

Code	ALARM STRING	Master	Slave	CONTROLLER STATUS			DESCRIPTION	Condition that has to occur to come out from alarm status
				Init	Stby	Motor running		
76	COIL SHORTED	X		X	X	X	<u>Alarm:</u> -Init: the LC and EB coil driver protection circuit is damaged - Stby or running: short on LC coil or EB coil	-If the alarm is present in Init status, remove the alarm cause -If the alarm has occurred in stby or running mode, it is necessary to remove alarm cause and to activate traction request
37	CONTACTOR CLOSED	X		X			<u>Alarm:</u> line contactor power contact is stuck	To remove alarm cause within a timeout; if the timeout is elapsed, it is necessary to re-cycle the key
38	CONTACTOR OPEN	X		X			<u>Alarm:</u> line contactor power contact does not pull-in	To remove alarm cause within a timeout; if the timeout is elapsed, it is necessary to re-cycle the key
82	ENCODER ERROR	X	X			X	<u>Alarm:</u> motor speed sensor (encoder) does not work properly	To recycle the key
84	STEER SENSOR KO	X		X	X	X	<u>Alarm:</u> steering poti signal out of range	To remove alarm cause
86	PEDAL WIRE KO		X	X	X	X	<u>Alarm:</u> fault in accelerator negative (NPOT) input circuit	To remove alarm cause and activate a traction request
245	WRONG SET BATTERY	X		X			<u>Alarm:</u> the battery voltage does not correspond to SET BATTERY programming	To remove alarm cause
246	SLAVE KO	X		X	X	X	<u>Alarm:</u> Master μ C detects a Slave μ C malfunctioning	To recycle the key

Co de	ALARM STRING	Ma ster	Slave	CONTROLLER STATUS			DESCRIPTION	Condition that has to occur to come out from alarm status
				Init	Stby	Motor running		
246	MASTER KO		X	X	X	X	<u>Alarm</u> : Slave μ C detects a Master μ C malfunctioning or a mismatch between inputs status and Master commands (via Canbus)	To recycle the key
250	INPUT MISMATCH		X	X	X	X	<u>Alarm</u> : Slave μ C has detected a mismatch between inputs status and the input status transmitted via Canbus by Master μ C	To recycle the key
253	AUX OUTPUT KO	X		X	X	X	<u>Alarm</u> : EB coil driver shorted or open	-If the alarm is present in Init status, remove the alarm cause -If the alarm has occurred in stby or running mode, it is necessary to remove alarm cause and to activate traction request
13	EEPROM KO	X	X	X	X	X	<u>Warning</u> : Eeprom fault, controller will use default parameters	To remove Warning cause
61	HIGH TEMPERA- TURE	X	X	X	X	X	<u>Warning</u> : Master or Slave or both temperature higher than 75°C	To remove Warning cause
65	MOTOR TEMPERA- TURE	X	X	X	X	X	<u>Warning</u> : Master or Slave or both motors temperature high	To remove Warning cause
66	BATTERY LOW	X		X	X	X	<u>Warning</u> : battery charge level below 20%	To remove Warning cause

Code	ALARM STRING	Master	Slave	CONTROLLER STATUS			DESCRIPTION	Condition that has to occur to come out from alarm status
				Init	Stby	Motor running		
78	VACC NOT OK	X		X	X		<u>Warning:</u> accelerator signal (CPOT) voltage higher than VACC MIN +1V while the traction enable switch is open	To remove Warning cause
79	INCORRECT START	X		X	X	X	<u>Warning:</u> wrong traction request sequence	To remove Warning cause
80	FORWARD + BACKWARD	X		X	X	X	<u>Warning:</u> forward and reverse inputs are both active	To remove Warning cause
249	THERMIC SENSOR KO	X	X	X	X	X	<u>Warning:</u> Master or slave temperature sensor is out of range	To remove Warning cause
251	WAITING FOR NODE#4	X		X	X	X	<u>Warning:</u> Master μ C signals that Slave μ C is in alarm status	To remove Warning cause
251	WAITING FOR NODE#3		X	X	X	X	<u>Warning:</u> Slave μ C signals that Master μ C is in alarm status	To remove Warning cause
247	NO CAN MESSAGE #4	X		X	X	X	<u>Alarm:</u> Master has lost Can communication with the Slave	To remove Warning cause
247	NO CAN MESSAGE #3		X	X	X	X	<u>Alarm:</u> Slave has lost Can communication with the Master	To remove alarm cause
244	SLAVE WARNING	X		X	X	X	<u>Warning:</u> Slave μ C has a warning	To remove Warning cause
250	HANDBRAKE	X			X	X	<u>Warning:</u> the operator try to travel with the handbrake active	To remove Warning cause

Code	ALARM STRING	Master	Slave	CONTROLLER STATUS			DESCRIPTION	Condition that has to occur to come out from alarm status
				Init	Stby	Motor running		
241	DATA ACQUISITION	X	X		X		<u>Warning:</u> Maximum current adjustment procedure is in progress (NOTE: this procedure has to be done only by Zapi test department)	To remove Warning cause and to activate traction request
248	CHECK UP NEEDED	X		X			<u>Warning:</u> maintenance time is reached	To remove Warning cause

10.2 Analysis of traction related alarms displayed on console

1) WATCH DOG

It is a self-diagnosis test within the logic between Master and Slave μ controllers. This alarm could also be caused by a canbus malfunctioning, which blinds Master-Slave communication. So, before replacing the controller, check the canbus.

2) LOGIC FAILURE #3

Fault in the hardware section of the logic board which manages the hardware current protection. Replace the logic board.

3) LOGIC FAILURE #2

Fault in the hardware section of the logic board which manages the phase' s voltage feedback. Replace the logic board.

4) LOGIC FAILURE #1

This alarm signals that the undervoltage / overvoltage protection interrupt has been triggered. Two possible reasons:

B) A real undervoltage / overvoltage situation happened.

C) Fault in the hardware section of the logic board which manages the overvoltage protection. Replace the logic card.

5) VMN LOW, VMN HIGH

The test is carried out during initial diagnosis and in standby.

Possible causes:

D) problem with the motor connections or the motor power circuit; check if the 3 phases are correctly connected; check if there's a dispersion of the motor to truck frame.

E) fault in the inverter power section, replace the controller.

6) STBY I HIGH

The μ Cs verify if the feedback of current sensors device output is within the zero current window. Possible causes of the alarm:

A) current sensor failure;

B) failure in the logic card: first replace the logic card; if the defect persists, replace the power unit.

7) CAPACITOR CHARGE

Follows the charging capacitor system:

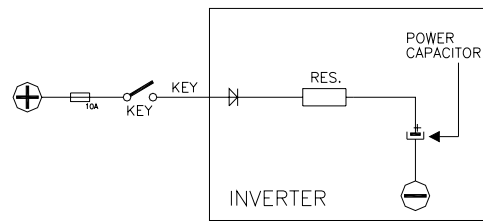

When the key is switched ON, the inverter tries to charge the capacitor through a power resistance, and check if the capacitor are charged within a timeout. If they do not charge, an alarm is signalled; the main contactor is not closed.

Possible reasons:

- A) the charging resistance is opened.
- B) The charging circuit has a failure.
- C) There is a problem in the power section.

8) MAIN CONTACTOR ALARMS

COIL SHORTED:

When the key is switched ON the μ Controller checks the LC coil driver shortcircuit protection hardware. If it does not react in a correct way to the μ C stimulus, the alarm is signalled. Replace the logic board. When the fault occurs while the LC is closed, the alarm signals a shortcircuit across LC coil. Check if there are external shortcircuit and if the ohmic value of the MC coil is correct; otherwise replace the logic.

DRIVER SHORTED:

When the key is switched ON, the μ C checks that the LC coil driver is not shorted; if it is, this alarm is signalled. Preliminary, check if there is an external short or low impedance pull-down between NLC (C26) and -BATT. If no external causes can be found out, replace the controller.

CONTACTOR DRIVER:

When the initial diagnosis is finished, the traction logic closes the LC and checks the voltage on the Drain of the driver. If this is not low, the driver is not able to close an alarm is signalled. Replace the logic.

CONTACTOR OPEN:

The main contactor coil has been driven by the logic board, but the contactor does not close. Two possible reasons:

- A) the wires to the coil are interrupted or not well connected.
- B) the contact of the contactor is not properly working (does not pull-in).

CONTACTOR CLOSED:

Before driving the LC coil, the controller checks if the LC contact is stuck. The controller drives the bridge for a while, trying to discharge the capacitor bank. If they don't discharge, the fault condition is entered. It is suggested to check the contactor contact, if it is mechanically stuck.

9) ENCODER ERROR

This alarm is signalled in following condition: the frequency supplied to the motor is higher than 20 Hz, and the signal feedback from the encoder has a jump higher than 20 Hz in few tens millisecond. This condition clearly shows a malfunctioning of the encoder signal. It is suggested to preliminary check the encoder wiring; if no fault is found in the wiring it is necessary to replace the encoder.

10) STEER SENSOR KO

This is an alarm which signals an out of range of the steering potentiometer signal. The fault condition is entered in these two following conditions:

- A) the "Set steer 0 pos" (straight wheels programming) parameter is wrong (lower than "Set steer min" or higher than "Set steer max").
- B) the feedback signal of the steering potentiometer is outside the window defined by "Set steer min" and "Set steer max" parameters.

In the first case, repeat the steering potentiometer acquisition. In the second case, check the steering poti and its wiring. Eventually, repeat again the steering potentiometer acquisition.

11) PEDAL WIRE KO

This alarm is signalled if a fault is detected in the accelerator unit wiring (NPOT or PPOT cable is interrupted).

12) WRONG SET BATTERY

When the key is turned ON, the controller check the battery voltage and compares it with the "SET BATTERY" parameter setting. If the actual value is 20% higher or lower than nominal value, the fault condition is entered. Replace the battery with a correct battery.

13) SLAVE KO

Slave and Master μ Cs perform a cross-check in order to verify their functionality. If the MASTER detects SLAVE μ C malfunctioning, it brings the controller in a safe status opening the power bridge and the Line Contactor.

14) MASTER KO

Slave and Master μ Cs perform a cross-check in order to verify their functionality. There are two conditions under which slave enters this fault condition:

- A) the SLAVE μ C receives incoherent can message from the MASTER μ C
- B) the SLAVE μ C compares the inputs status and the related MASTER operations, and find they are not coherent.

In both cases, the SLAVE brings the controller to a safe status opening the power bridge and the Line contactor.

15) INPUT MISMATCH

Safety related inputs (Fw direction, Rev direction, accelerator ENABLE, SEAT switch) are input to both microcontrollers by independent hw circuit. The two μ Cs read these inputs and compare by exchanging related status on the canbus. If the SLAVE μ C finds a mismatch between its inputs and MASTER inputs, it brings the controller to a safe status opening the power bridge and the Line contactor.

16) AUX OUTPUT KO

The μ P checks the driver of the electromechanical brake coil. If the status of the driver output does not correspond to the signal coming from the μ P, the alarm is signalled. It is suggested to preliminary check if there is an external short or low impedance pull-down between NAUX (C31) and -BATT. If no external cause can be found, replace the logic card.

17) EEPROM KO

Fault in the area of memory in which the adjustment parameters are stored; this alarm does not inhibits truck operation, but the controller will use default parameters. If the defect persists when the key is switched OFF and ON again, replace the logic. If the alarm disappears, remember that the parameters stored previously have been cancelled and replaced by the default values.

18) HIGH TEMPERATURE

Master or Slave or both temperatures are greater than 75°C. The maximum current is reduced proportionally to the temperature increase. At 100°C the max current of both inverter is reduced to zero.

If the alarm is signalled when the controller is cold:

- A) thermal sensor failure;
- B) failure in the logic card.

19) MOTOR TEMPERATURE

This warning is signalled if right or left or both motors temperature switches open (digital sensor) or if the analog signals overtakes the cut off level. If it happens when the motor is cold, check the wiring. If all is ok, replace the logic board.

20) BATTERY LOW

If the "battery check" option is ON, a battery discharge algorithm is carried out. When the charge level is 20% , this alarm is signalled and the current is reduced to the half of the programmed level.

21) VACC NOT OK

The test is made in standby. This alarm indicates that the accelerator voltage is 1 V greater than the minimum value programmed by the PROGRAM VACC function.

Possible causes:

- A) the potentiometer is not correctly calibrated;
- B) the potentiometer is defective.

22) INCORRECT START

This alarm signals an incorrect starting sequence. Possible causes:

- A) Fw or Rev or Enable microswitch failure;
- B) error in sequence made by the operator;
- C) incorrect wiring;
- D) if the default persists after checking the harness, replace the logic.

23) FORW + BACK

The test is carried out continuously. An alarm is signalled when a double running request is made simultaneously. Possible causes:

- A) defective wiring;
- B) running microswitch failure;
- C) incorrect operation;
- D) if the defect persists, replace the logic.

24) THERMIC SENSOR KO

The range of inverter temperature sensor is always checked and a warning is signalled if it is out of range.

When this alarm is signalled, the maximum current of the controller is reduced to half.

25) WAITING FOR NODE #4

The Slave has detected a failure, the Master cannot close the main contactor because of the alarm status of the Slave (which the Master knows by the CAN-BUS line). The failure must be looked for in the Slave controller, use the remote console to get connection to the Slave μ C.

26) WAITING FOR NODE #3

The Master μ C has detected a fault condition, the Slave is aware of this thanks to canbus communication; it cannot drive the motor until the Master has resolved its problem. The fault has to be looked for in the Master.

27) NO CAN MESSAGE #4

Master (node #3) signals that it has lost can communication with the Slave (node #4). This fault could be determined by a problem in the truck canbus line or by an internal problem in the controller logic card.

It is suggested to preliminary check canbus connection.

28) NO CAN MESSAGE #3

Slave (node #4) signals that it has lost can communication with the Master (node #3). This fault could be determined by a problem in the truck canbus line or by an internal problem in the controller logic card.

It is suggested to preliminary check canbus connection.

29) SLAVE WARNING

The slave has a warning. Connect to the slave with the hand set console and check the warning.

30) HANDBRAKE

This warning occurs when the operator try to travel with the handbrake active. Possible causes:

- A) handbrake microswitch failure;
- B) incorrect wiring;
- C) if the defect persists, replace the logic.

31) DATA ACQUISITION

This warning signals that the inverter is in the acquisition of the current gains phase; it ends when the acquisition is done.

32) CHECK UP NEEDED

This is just a warning to call for the time programmed maintenance. It is just enough to turn the CHECK UP DONE option to level ON after the maintenance is executed.

10.3 Pump related fault codes

Code	ALARM STRING	Master	Slave	CONTROLLER STATUS			DESCRIPTION	Condition that has to occur to come out from alarm status
				Init	Stby	Motor running		
28	PUMP VMN LOW		X	X	X	X	<u>Alarm</u> : wrong voltage output of pump chopper; the motor voltage feedback is not coherent with applied PWM	-If the alarm is present in Init status, remove the alarm cause -If the alarm has occurred in stby or running mode, it is necessary to remove the fault cause and to activate a function request
56	PUMP STBY I HIGH		X	X	X		<u>Alarm</u> : in stby condition (no PWM applied to pump chopper), the pump current sensor feedback is out of the zero current window	-If the alarm is present in Init status, remove the alarm cause -If the alarm has occurred in stby or running mode, it is necessary to remove the fault cause and to activate a function request
242 Slave	PUMP TEMPERAT.		X	X	X	X	<u>Warning</u> : the pump chopper temperature is higher than 75°C	To remove warning cause

Code	ALARM STRING	Master	Slave	CONTROLLER STATUS			DESCRIPTION	Condition that has to occur to come out from alarm status
				Init	Stby	Motor running		
242 Master	PUMP WARNING	X		X	X	X	<u>Warning:</u> Master controller signals that Slave μ C has detected a fault in the pump chopper	To remove warning cause
243	PUMP INC. START		X	X	X		<u>Warning:</u> pump chopper incorrect start sequence	To remove warning cause
244	PUMP VACC NOT OK		X	X	X		<u>Warning:</u> pump chopper accelerator voltage is 1V greater than the minimum value programmed	To remove warning cause
245	PUMP TH. SENS. KO		X	X	X	X	<u>Warning:</u> pump chopper temperature sensor is out of range	To remove Warning cause

10.4 Analysis of pump related alarms displayed on console

1) PUMP VMN LOW

The pump chopper power output is feedback to the μ C. If this feedback voltage is not coherent with the applied PWM, this fault condition is signalled. There could be many causes:

- failure in the pump chopper power section
- failure in the pump chopper driving section
- failure in the pump chopper voltage feedback circuit
- dispersion in the pump motor to truck frame.

2) PUMP STBY I HIGH

The pump chopper current sensor feedback is out of the zero-current window while no PWM is applied to the pump chopper. The most likely cause is a failure in the current sensor.

3) PUMP TEMPERATURE

Pump chopper temperature is higher than 75°C, maximum current is proportionally reduced. If the alarm is present when the controller is cold, there is a failure in the temperature sensor or in the feedback circuit.

4) PUMP WARNING

This is a warning in the MASTER controller, which inform that the SLAVE is in a pump chopper related fault condition.

5) PUMP INC. START

This is a warning in the pump chopper, which inform that an incorrect start sequence happened on the pump.

6) PUMP VACC NOT OK

This is a warning in the pump chopper, which inform that accelerator voltage is 1 V grater than the minimum value programmed.

7) PUMP TH. SENS. KO

The range of pump chopper temperature sensor is always checked and a warning is signalled if it is out of range.

When this warning is signalled, the maximum current of the pump chopper is reduced to half.

11 RECOMMENDED SPARE PARTS FOR INVERTER

Part Number	Description
C16507	Protected 500 A strip Fuse
C16505	Protected 355 A strip Fuse
C16520	10 A 20 mm Control Circuit Fuse
C29523	SW 180 80 V Single Pole Contactor
C29522	SW 180 48 V Single Pole Contactor
C29508	SW 180 24 V Single Pole Contactor
C12529	Ampseal Connector 8 pins Female
C12532	Ampseal Connector 35 pins Female
C12530	Ampseal Connector 14 pins Female
C12796	Female pin harness side

12 PERIODIC MAINTENANCE TO BE REPEATED AT TIMES INDICATED

Check the wear and condition of the Contactors' moving and fixed contacts. Electrical Contacts should be checked every **3 months**.

Check the Foot pedal or Tiller microswitch. Using a suitable test meter, confirm that there is no electrical resistance between the contacts by measuring the volt drop between the terminals. Switches should operate with a firm click sound. Microswitches should be checked every **3 months**.

Check the Battery cables, cables to the inverter, and cables to the motor. Ensure the insulation is sound and the connections are tight. Cables should be checked every **3 months**.

Check the mechanical operation of the pedal or tiller. Are the return springs ok. Do the potentiometers wind up to their full or programmed level. Check every **3 months**.

Check the mechanical operation of the Contactor(s). Moving contacts should be free to move without restriction. Check every **3 months**.

Checks should be carried out by qualified personnel and any replacement parts used should be original. Beware of NON ORIGINAL PARTS. The installation of this electronic controller should be made according to the diagrams included in this Manual. Any variations or special requirements should be made after consulting a Zapi Agent. The supplier is not responsible for any problem that arises from wiring methods that differ from information included in this Manual.

During periodic checks, if a technician finds any situation that could cause damage or compromise safety, the matter should be brought to the attention of a Zapi Agent immediately. The Agent will then take the decision regarding operational safety of the machine.

Remember that Battery Powered Machines feel no pain.

NEVER USE A VEHICLE WITH A FAULTY ELECTRONIC CONTROLLER.